

3.1

IEC Contactors and Starters

XT IEC Power Control

3

IEC Non-Metallic Enclosure—Contactors and Starters



Non-Metallic Enclosure—Contactors and Starters

Product Description

XT non-metallic 4X starters are the latest addition to our broad line of pre-engineered solutions that make it easy to get an enclosed starter fast! These sturdy, uncomplicated starters are economical, but built to last. Components are all housed in a dust-tight, rain-tight, oil-tight, water-tight and corrosion resistant polycarbonate insulated enclosure. In most cases, **XT** non-metallic 4X starters are available from stock for next day delivery.

Reliable Protection

Each starter features an Eaton **XT** IEC thermal overload relay. Fourteen overload sizes are available to complete the starter, providing adjustable

settings for 0.1 to 32 full load amps. Because of its direct mount design, the **XT** relay and resulting starter command a very small footprint.

Clever, Convenient Design to 25 hp

Six different base models (single- and three-phase) are available, ranging from fractional to 25 hp units (at 575 V). This allows you to closely match the starter to your application.

Each starter is equipped with a telescopic base-mount for the pilot device contact blocks. This eliminates all wiring between the cover and starter base, making commissioning and troubleshooting a snap.

Additional Reference

Cover Control	V10-T3-3
Dimensions	Tab 14
Accessories and Modifications	Tab 15
Renewal Parts	Tab 16
Technical Data and Specifications	Tab 17

Contents

Description	Page
Non-Metallic Enclosure—Contactors and Starters	
Catalog Number Selection	V10-T3-3
Cover Control Options	V10-T3-3
Product Selection	V10-T3-4
Metallic Enclosure—Contactors and Starters	V10-T3-8
Combination Motor Controllers	V10-T3-43

Features and Benefits

- Single- and three-phase enclosed starters to 25 hp (at 575 V)
- Rugged IP65 polycarbonate enclosure equivalent to NEMA 1, 12, 13, 3R and 4X environmental protection
- All starters feature the modern **XT** contactor family from Eaton in your choice of control voltage from 24 Vac to 600 Vac
- Class 10 motor protection is provided by adjustable bimetal overload relays
- Standard starters feature START/STOP double pushbuttons and a RESET selected from our rugged M22 pilot device line
- Other control options include OFF–ON or HAND–0–AUTO selector switches, with or without pilot light
- All starters use electrical operators to energize and de-energize the starter, providing longer component lifespan and the option for two-wire control
- 5 hp starters are only six inches high; 25 hp starters are less than 10 inches high

Standards and Certifications

Note: See **Tab 17** for additional information on standards and certifications that apply to all enclosed control products.

- UL Listed/CSA/IEC

Product Configuration Overview

Starter sizes (mm)

- To 5 hp (at 575 V): 160 x 100 x 145 (L x W x D)
- To 20 hp (at 575 V): 200 x 120 x 160 (L x W x D)
- To 25 hp (at 575 V): 240 x 160 x 160 (L x W x D)

Phases

- Available in single- and three-phase

Contactors

- From miniature to 32 amps

Voltages

- 50 Hz: 110 V, 23 V, 415 V
- 60 Hz: 24 V, 120 V, 208 V, 240 V, 480 V, 600 V

Pilot devices

- START/STOP double-pushbutton
- ON–OFF selector switch
- HAND–0–AUTO selector switch

Illumination options

- Red light 85–264 Vac
- Red light 12–30 Vac/Vdc
- Without illumination

Catalog Number Selection

XT IEC Line Non-Metallic Enclosed Control

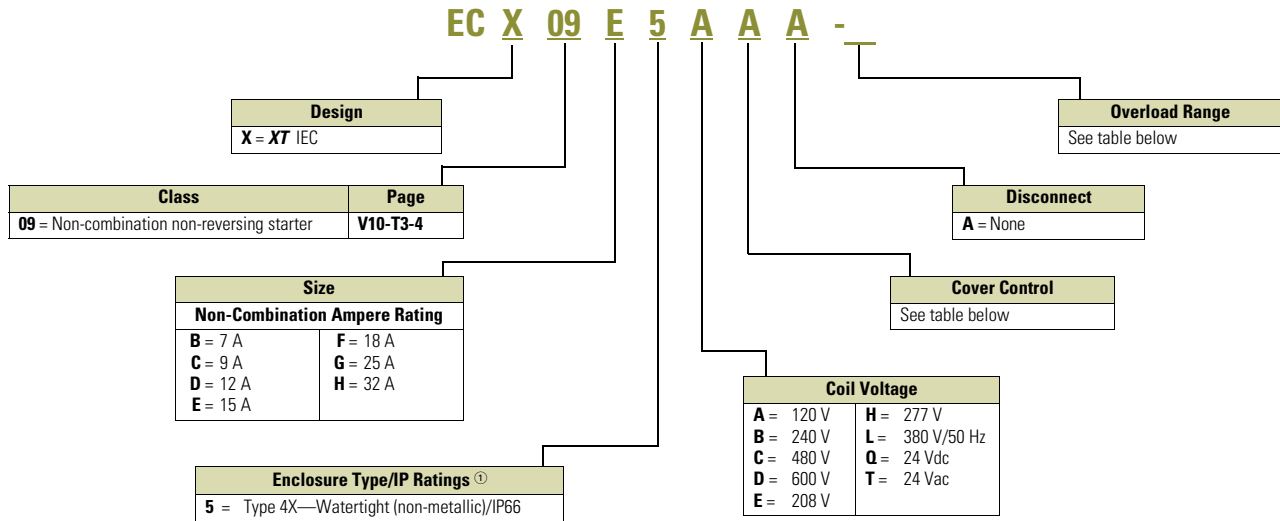

XTOB Overload Relays for Enclosed XT

FLA Ratings	Size B–E 7–15 A	Size F–H 18–32 A	FLA Ratings	Size B–E 7–15 A	Size F–H 18–32 A
0.1–0.16	A	A	4–6	I	I
0.16–0.24	B	B	6–10	J	J
0.24–0.4	C	C	9–12	K	—
0.4–0.6	D	D	10–16	—	L
0.6–1	E	E	12–16	L	—
1–1.6	F	F	16–24	—	M
1.6–2.4	G	G	24–32	—	N
2.4–4	H	H			

XTOE Electronic Overload Relays for Enclosed XT

FLA Ratings	Size B–E 7–15 A	Size F–H 18–32 A
0.33–1.65	R63/A	R63/A
1–5	R63/B	R63/B
4–20	R63/C	R63/C
9–45	—	R63/D

Cover Control Options



Cover Control Options

Description	Position 9 Control Code
No cover mounted pilot devices	A
START/STOP pushbuttons	B
With red RUN pilot light	C
HAND/OFF/AUTO selector switch	H
With red RUN pilot light	J
ON/OFF selector switch	S
With red RUN pilot light	T

Note

Ⓢ See **Tab 1** for enclosure type/IP rating cross-reference.

3.1

IEC Contactors and Starters

XT IEC Power Control

Product Selection

CI-K Basic Enclosures

CI-K Basic Enclosures ①②

Dimensions in Inches (mm)



3

Width	Height	External Depth	Internal Depth	Internal Mounting Type	Pkg. Qty.	Catalog Number
3.94 (100.0)	6.30 (160.0)	3.94 (100.0)	2.87 (73.0)	With mounting rail	1	CI-K2X-100-TS-NA ③
			3.11 (79.0)	With mounting plate		CI-K2X-100-M-NA ③
			5.71 (145.0)	With mounting rail		CI-K2X-145-TS-NA ③
			4.88 (124.0)	With mounting plate		CI-K2X-145-M-NA ③
4.72 (120.0)	7.87 (200.0)	4.92 (125.0)	3.66 (93.0)	With mounting rail	1	CI-K3X-125-TS-NA ④
			3.86 (98.0)	With mounting plate		CI-K3X-125-M-NA ④
			6.30 (160.0)	With mounting rail		CI-K3X-160-TS-NA ④
			5.24 (133.0)	With mounting plate		CI-K3X-160-M-NA ④
6.30 (160.0)	9.45 (240.0)	6.30 (160.0)	5.04 (128.0)	With mounting rail	1	CI-K4X-160-TS-NA ④
			5.24 (133.0)	With mounting plate		CI-K4X-160-M-NA ④
7.87 (200.0)	11.02 (280.0)	6.30 (160.0)	5.04 (128.0)	With mounting rail	1	CI-K5X-160-TS-NA ④
			5.24 (133.0)	With mounting plate		CI-K5X-160-M-NA ④

Class ECX09—Non-Metallic Non-Combination Non-Reversing Contactor ONLY

Amps	Maximum hp ⑤		Coil Voltage at 60 Hz ⑦	Type 4X/IP66 Catalog Number	Component Catalog Number
	Motor Voltage ⑥	Single-Phase			
Size B					
7	115	1/4	—	120	ECX09B5AAA XTCE007B10A
	208	3/4	1-1/2	208	ECX09B5EAA XTCE007B10E
	230	1	2	240	ECX09B5BAA XTCE007B10B
	380	—	3	380/50 Hz	ECX09B5LAA XTCE007B10L
	460	—	3	480	ECX09B5CAA XTCE007B10C
	575	—	5	600	ECX09B5DAA XTCE007B10D
Size C					
9	115	1/2	—	120	ECX09C5AAA XTCE009B10A
	208	1	2	208	ECX09C5EAA XTCE009B10E
	230	1-1/2	3	240	ECX09C5BAA XTCE009B10B
	380	—	5	380/50 Hz	ECX09C5LAA XTCE009B10L
	460	—	5	480	ECX09C5CAA XTCE009B10C
	575	—	7-1/2	600	ECX09C5DAA XTCE009B10D
Size D					
12	115	1/2	—	120	ECX09D5AAA XTCE012B10A
	208	1-1/2	3	208	ECX09D5EAA XTCE012B10E
	230	2	3	240	ECX09D5BAA XTCE012B10B
	380	—	5	380/50 Hz	ECX09D5LAA XTCE012B10L
	460	—	7-1/2	480	ECX09D5CAA XTCE012B10C
	575	—	10	600	ECX09D5DAA XTCE012B10D
Size E					
15	115	3/4	—	120	ECX09E5AAA XTCE015B10A
	208	2	3	208	ECX09E5EAA XTCE015B10E
	230	2	3	240	ECX09E5BAA XTCE015B10B
	380	—	5	380/50 Hz	ECX09E5LAA XTCE015B10L
	460	—	7-1/2	480	ECX09E5CAA XTCE015B10C
	575	—	10	600	ECX09E5DAA XTCE015B10D

Notes

- ① Enclosure base RAL 9005, black/enclosure top only RAL 7035. Light gray.
- ② Degree of protection—IEC: IP65; UL/CSA: Type 1, 3R, 4X, 12, 13—indoor and outdoor use.
- ③ CI-K2X_: 4 x 1/2 inch knockouts.
- ④ CI-K3X_, CI-K4X_, CI-K5X_: Smooth overall with sharp corners.
- ⑤ 1 hp = 0.746 kW.
- ⑥ Contact factory for other voltage options.
- ⑦ Voltage is listed at 60 Hz unless otherwise noted. Other voltages available upon request.

Class ECX09—Non-Metallic Non-Combination Non-Reversing Contactor ONLY, continued

Amps	Maximum hp ^①		Coil Voltage at 60 Hz ^③	Type 4X/IP66 Catalog Number	Component Catalog Number	
	Motor Voltage ^②	Single-Phase				Three-Phase
Size F						
18	115	2	—	120	ECX09F5AAA	XTCE018C10A
	208	2	5	208	ECX09F5EAA	XTCE018C10E
	230	3	5	240	ECX09F5BAA	XTCE018C10B
	380	—	7-1/2	380/50 Hz	ECX09F5LAA	XTCE018C10L
	460	—	10	480	ECX09F5CAA	XTCE018C10C
	575	—	15	600	ECX09F5DAA	XTCE018C10D
Size G						
25	115	2	—	120	ECX09G5AAA	XTCE025C10A
	208	3	7-1/2	208	ECX09G5EAA	XTCE025C10E
	230	5	7-1/2	240	ECX09G5BAA	XTCE025C10B
	380	—	10	380/50 Hz	ECX09G5LAA	XTCE025C10L
	460	—	15	480	ECX09G5CAA	XTCE025C10C
	575	—	20	600	ECX09G5DAA	XTCE025C10D
Size H						
32	115	3	—	120	ECX09H5AAA	XTCE032C10A
	208	5	10	208	ECX09H5EAA	XTCE032C10E
	230	5	10	240	ECX09H5BAA	XTCE032C10B
	380	—	15	380/50 Hz	ECX09H5LAA	XTCE032C10L
	460	—	20	480	ECX09H5CAA	XTCE032C10C
	575	—	25	600	ECX09H5DAA	XTCE032C10D

Notes

- ① 1 hp = 0.746 kW.
 ② Contact factory for other voltage options.
 ③ Voltage is listed at 60 Hz unless otherwise noted. Other voltages available upon request.

3.1

IEC Contactors and Starters

XT IEC Power Control

Class ECX09—Non-Metallic Non-Combination Non-Reversing Starter

Amps	Maximum hp ^①		Coil Voltage at 60 Hz ^③	Type 4X/IP66	Component
	Motor Voltage ^②	Single-Phase		Three-Phase	Catalog Number ^④
Size B					
7	115	1/4	—	120	ECX09B5AAA- XTAE007B10A
	208	3/4	1-1/2	208	ECX09B5EAA- XTAE007B10E
	230	1	2	240	ECX09B5BAA- XTAE007B10B
	380	—	3	380/50 Hz	ECX09B5LAA- XTAE007B10L
	460	—	3	480	ECX09B5CAA- XTAE007B10C
	575	—	5	600	ECX09B5DAA- XTAE007B10D
Size C					
9	115	1/2	—	120	ECX09C5AAA- XTAE009B10A
	208	1	2	208	ECX09C5EAA- XTAE009B10E
	230	1-1/2	3	240	ECX09C5BAA- XTAE009B10B
	380	—	5	380/50 Hz	ECX09C5LAA- XTAE009B10L
	460	—	5	480	ECX09C5CAA- XTAE009B10C
	575	—	7-1/2	600	ECX09C5DAA- XTAE009B10D
Size D					
12	115	1/2	—	120	ECX09D5AAA- XTAE012B10A
	208	1-1/2	3	208	ECX09D5EAA- XTAE012B10E
	230	2	3	240	ECX09D5BAA- XTAE012B10B
	380	—	5	380/50 Hz	ECX09D5LAA- XTAE012B10L
	460	—	7-1/2	480	ECX09D5CAA- XTAE012B10C
	575	—	10	600	ECX09D5DAA- XTAE012B10D
Size E					
15	115	3/4	—	120	ECX09E5AAA- XTAE015B10A
	208	2	3	208	ECX09E5EAA- XTAE015B10E
	230	2	3	240	ECX09E5BAA- XTAE015B10B
	380	—	5	380/50 Hz	ECX09E5LAA- XTAE015B10L
	460	—	7-1/2	480	ECX09E5CAA- XTAE015B10C
	575	—	10	600	ECX09E5DAA- XTAE015B10D

Notes

- ① 1 hp = 0.746 kW.
- ② Contact factory for other voltage options.
- ③ Voltage is listed at 60 Hz unless otherwise noted. Other voltages available upon request.
- ④ Select proper "XTOB" or "XTOE" overload amperage range as per motor FLA, see **Page V10-T3-3**.
- ⑤ For complete component Catalog Number, see **Volume 5—Motor Control and Protection, CA08100005E, Tab 27**.

Class ECX09—Non-Metallic Non-Combination Non-Reversing Starter, continued

Amps	Maximum hp ^①		Coil Voltage at 60 Hz ^③	Type 4X/IP66 Catalog Number ^④	Component Catalog Number ^⑤
	Motor Voltage ^②	Single-Phase			
Size F					
18	115	2	—	120	ECX09F5AAA-_ XTAE018C10A_
	208	2	5	208	ECX09F5EAA-_ XTAE018C10E_
	230	3	5	240	ECX09F5BAA-_ XTAE018C10B_
	380	—	7-1/2	380/50 Hz	ECX09F5LAA-_ XTAE018C10L_
	460	—	10	480	ECX09F5CAA-_ XTAE018C10C_
	575	—	15	600	ECX09F5DAA-_ XTAE018C10D_
Size G					
25	115	2	—	120	ECX09G5AAA-_ XTAE025C10A_
	208	3	7-1/2	208	ECX09G5EAA-_ XTAE025C10E_
	230	5	7-1/2	240	ECX09G5BAA-_ XTAE025C10B_
	380	—	10	380/50 Hz	ECX09G5LAA-_ XTAE025C10L_
	460	—	15	480	ECX09G5CAA-_ XTAE025C10C_
	575	—	20	600	ECX09G5DAA-_ XTAE025C10D_
Size H					
32	115	3	—	120	ECX09H5AAA-_ XTAE032C10A_
	208	5	10	208	ECX09H5EAA-_ XTAE032C10E_
	230	5	10	240	ECX09H5BAA-_ XTAE032C10B_
	380	—	15	380/50 Hz	ECX09H5LAA-_ XTAE032C10L_
	460	—	20	480	ECX09H5CAA-_ XTAE032C10C_
	575	—	25	600	ECX09H5DAA-_ XTAE032C10D_

Notes

① 1 hp = 0.746 kW.

② Contact factory for other voltage options.

③ Voltage is listed at 60 Hz unless otherwise noted. Other voltages available upon request.

④ Select proper "XTOB" or "XTOE" overload amperage range as per motor FLA, see **Page V10-T3-3**.

⑤ For complete component Catalog Number, see **Volume 5—Motor Control and Protection, CA08100005E, Tab 27**.

IEC Metallic Enclosure—Contactors and Starters



3

Contents

<i>Description</i>	<i>Page</i>
Non-Metallic Enclosure—Contactors and Starters . . .	V10-T3-2
Metallic Enclosure—Contactors and Starters	
Catalog Number Selection	V10-T3-9
Product Selection	
Non-Combination Starters	V10-T3-14
Combination Starters	V10-T3-23
Wiring Diagrams	V10-T3-35
Combination Motor Controllers	V10-T3-43

Metallic Enclosure—Contactors and Starters

Product Description

Eaton's **XT** line includes IEC contactors, starters and combination motor controllers (CMCs). Designed to meet international standards, the enclosed control **XT** line (ECX), carries UL and cUL certifications.

Features and Benefits

- AC control from 12 V to 600 V 50/60 Hz
- DC control from 24 V to 220 V
- Available with screw or spring cage terminals
- Reversing or non-reversing contactors and starters
- AC-3 contactor ratings to 1000 A and AC-1 contactor ratings to 2000 A
- Non-reversing starters to 650 A
- Panel or DIN rail mounting to 65 A
- IP20 finger and back-of-hand proof
- Large ambient temperature range, -25 °C to +50 °C [-13 °F to +122 °F]

- AC and DC controlled contactors in the same compact frame
- Low power consumption DC coils
- Built-in NO or NC auxiliary contacts to 32 A
- Plug-in accessories for reduced installation time
- Types 1 (IP23), 4 (IP66), 4X (IP66), 12 (IP65) and 3R (IP32)
- Circuit breakers, fused, non-fused and non-combination designs available
- Opaque (standard) or clear covers available on non-metallic Halyester enclosure option

Standards and Certifications

Note: See **Tab 17** for additional information on standards and certifications that apply to all enclosed control products.

- Fusible—with Class J fuses
 - UL Listed
 - cUL Listed ①
- Circuit Breaker HMCP/E
 - UL Listed
 - cUL Listed ①

Short-Circuit Ratings

- Fused, non-fused
 - 10K AIC at 600 V
- HMCP
 - 0–10 hp 15K AIC at 600 V
 - 15–125 hp 25K AIC at 600 V
- Non-combination
 - 0–1 hp 1K AIC at 600 V
 - 1.5–50 hp 5K AIC at 600 V
 - 50–200 hp 10K AIC at 600 V

Note

① cUL Listing indicates appropriate CSA standard investigation.

Additional Reference

Dimensions	Tab 14
Accessories and Modifications	Tab 15
Renewal Parts	Tab 16
Technical Data and Specifications	Tab 17

Catalog Number Selection

XT IEC Line Metallic Enclosed Control

EC X 25 E 5 A A A -

Design
X = XT IEC

Modification Codes
See Tab 15

Class	Page
09= Non-combination non-reversing starter	V10-T3-14
10= Non-combination reversing starter	V10-T3-17
11= Non-combination non-reversing starter with CPT	V10-T3-20
19= Combination non-reversing starter—fusible/non-fusible disconnect	V10-T3-23
20= Combination reversing starter—fusible/non-fusible disconnect	V10-T3-26
25= Combination non-reversing starter—circuit breaker	V10-T3-29
26= Combination reversing starter—circuit breaker	V10-T3-32

Overload Range
See table below

Disconnect Fuse Clip Ratings	
A = None	
C = 30 A J	
E = 60 A J	
G = 100 A J	
Circuit Breaker Ratings	
A = None	F = 50 A
B = 3 A	W = 70 A
C = 7 A	G = 100 A
D = 15 A	H = 150 A
E = 30 A	J = 250 A

Size	
Combination (Class 16–74)	Non-Combination (Class 09–11) Ampere Rating (UL 600 V)
IEC Size B–Q	B = 7 A J = 40 A C = 9 A K = 50 A D = 12 A L = 65 A E = 15 A M = 80 A F = 18 A N = 95 A G = 25 A P = 115 A H = 32 A Q = 150 A

Enclosure Type/IP Ratings ①
1 = Type 1—General purpose/IP23
3 = Type 4—Painted steel/IP66
4 = Type 4X—Watertight (304-Grade stainless steel)/IP66
5 = Type 4X—Watertight (non-metallic)/IP66
8 = Type 12—Dust-tight/IP65

Cover Control
Type 1 non-comb. (NEW BOX 1 only) starters see Page V10-T3-11
Type 1 non-comb. starters see Page V10-T3-12
All other starters see Page V10-T3-14

Coil Voltage
A = 120 V H = 277 V
B = 240 V L = 380 V / 50 Hz
C = 480 V Q = 24 Vdc
D = 600 V T = 24 Vac
E = 208 V

XTOB Overload Relays for Enclosed XT

FLA Ratings	Size B–E 7–15 A	Size F–H 18–32 A	Size J–L 40–65 A	Size M–N 80–95 A	Size P–Q 115–150 A
0.1–0.16	A	A	—	—	—
0.16–0.24	B	B	—	—	—
0.24–0.4	C	C	—	—	—
0.4–0.6	D	D	—	—	—
0.6–1	E	E	—	—	—
1–1.6	F	F	—	—	—
1.6–2.4	G	G	—	—	—
2.4–4	H	H	—	—	—
4–6	I	I	—	—	—
6–10	J	J	J	—	—
9–12	K	—	—	—	—
12–16	L ②	L	L	—	—

FLA Ratings	Size B–E 7–15 A	Size F–H 18–32 A	Size J–L 40–65 A	Size M–N 80–95 A	Size P–Q 115–150 A
16–24	—	M	M	—	—
24–32	—	N	—	—	—
24–40	—	—	P	—	—
25–35	—	—	—	S	S
35–50	—	—	—	T	T
40–57	—	—	Q	—	—
50–65	—	—	R	—	—
50–70	—	—	—	U	U
70–100	—	—	—	V	V
95–125	—	—	—	—	W
120–150	—	—	—	—	X

Notes

- ① See Tab 1 for enclosure type/IP rating cross-reference.
- ② Size B–E is 10–16 A.

C440 Solid-State Overload Modifications

Reliability and Improved Uptime

- C440 provides the users with peace of mind knowing that their assets are protected with the highest level of motor protection and communication capability in its class
- Extends the life of plant assets with selectable motor protection features such as trip class, phase unbalance and ground fault
- Protects against unnecessary downtime by discovering changes in your system (line/load) with remote monitoring capabilities
- Status LED provides added assurance that valuable assets are protected by indicating the overload operational status

Flexibility

- Improves return on investment by reducing inventory carrying costs with wide FLA adjustment (5:1) and selectable trip class
- Design incorporates built-in ground fault protection thus eliminating the need for separate CTs and modules
- Flexible communication with optional I/O enables easy integration into plant management systems for remote monitoring and control

Monitoring Capabilities

- Individual phase currents RMS
- Average three-phase current RMS
- Thermal memory
- Fault indication (overload, phase loss, phase unbalance, ground fault)

Safety

- IP20 rated terminal blocks
- Available in Eaton's industry leading FlashGard MCCs
- Tested to the highest industry standards such as UL, CSA, CE and IEC
- RoHS compliant

For solid-state overload enclosed control, add R63 or R64 modification code after the base Catalog Number. (Example, ECX09G1AAA-**R63/B**).

Modification	IEC Size	NEMA Size	Full Load Current Adjustment Range (A)	Three-Phase without Ground Fault Auto/Manual Reset Overload Selectable Class 10/20/30	Three-Phase with Ground Fault Auto/Manual Reset Overload Selectable Class 10/20/30
Solid-state electronic overload relay ^①	B and C	00	0.33–1.65 ^②	R63/A	R64/A
			1–5	R63/B	R64/B
			4–20	R63/C	R64/C
	C and D	0 and 1	0.33–1.65 ^②	R63/A	R64/A
			1–5	R63/B	R64/B
			4–20	R63/C	R64/C
			9–45	R63/D	R64/D
	D	2	9–45	R63/D	R64/D
	D, F and G	3	20–100	R63/E	R64/E
G	4	28–140	R63/F	R64/F	
N/A	5	60–300	R63/G	R64/G	
N/A	6	120–600	R63/H	R64/H	

Notes

- ^① Features:
- Self-powered
 - Phase loss protection
 - Current adjustment knob
 - ±1% repeat accuracy
 - 1NO and 1NC isolated contacts
- ^② Not UL Listed.

Cover Control

Product Selection

Type 1 Non-Combination Cover Control (Box 1 Only)

- Cover control for non-combination starters uses M22 style devices as standard
- Pushbuttons are momentary type
- Field convertible selector switches from momentary to maintained operation and vice versa
- Cover control kits include hardware, M22 pushbuttons, bracket and pre-wired wire harnesses
- See Volume 7, Tab 1, for more details on M22 pushbuttons

Type 1 Non-Combination Cover Control (Box 1 Only)

Box 1 offering includes metallic enclosures with starters up to 32 A.



Description	Factory Installed	Field Installation Kits
	Flange Control Position 9 Cover Control Code	Catalog Number
Non-Reversing		
No cover mounted pilot devices	A	—
STOP/START oval pushbuttons	B	C600M1
With red RUN pilot light	C	C600M101 ^①
With red RUN/green OFF lights	D	C600M102 ^①
OFF/ON oval pushbuttons	E	C600M2
With red RUN pilot light	F	C600M201 ^①
With red RUN/green OFF lights	G	C600M202 ^①
STOP/START selector switch	S	C600M13
With red RUN pilot light	T	C600M131 ^①
With red RUN/green OFF lights	U	C600M132 ^①
OFF/ON selector switch	V	C600M14
With red RUN pilot light	W	C600M141 ^①
With red RUN/green OFF lights	X	C600M142 ^①
HAND/OFF/AUTO selector switch	H	C600M12
With red RUN pilot light	J	C600M121 ^①
With red RUN/green OFF lights	K	C600M122 ^①
Green START pushbutton	L	C600M3
Red STOP pushbutton	Y	C600M7 ^①
Green ON pushbutton	M	C600M4
Red OFF pushbutton	N	C600M5
Red RUN pilot light	P	C600M9 ^①
Green OFF pilot light	Q	C600M10 ^①
Red RUN/green OFF lights	R	C600M11 ^①
TEST/OFF/AUTO selector switch	—	C600M8
Reversing		
UP/STOP/DOWN selector switch	E	C600M27
With 2 red pilot lights	F	C600M271 ^①
REV/STOP/FWD selector switch	H	C600M15
With 2 red pilot lights	J	C600M151 ^①
Two red pilot lights (labeled FWD, REV)	P	C600M28 ^①
Green OFF pilot light	Q	C600M10 ^①

Note

^① Add code letter from the table below to catalog number for voltage. Example: C600M101A.

Rating	Code Letter
85–264 Vac	A
480 Vac	C
12–30 Vac/Vdc	T

3.1

IEC Contactors and Starters

XT IEC Power Control

3

Type 1 Non-Combination Cover Control (Box 2 and Larger Enclosures Only)

- Cover control for combination starters uses 10250T style devices as standard
- Selector switches are maintained with lever operators
- Pushbuttons are momentary type with extended pushbutton
- The kit includes hardware and connecting wires (where possible)
- For factory installed control devices other than shown below, refer to modification codes, **Tab 15**

Type 1 Cover Control



Type 1 Non-Combination Cover Control (Box 2 and Larger Enclosures Only)

Box 2 and Larger Enclosure offering includes metallic enclosures with starters larger than 32 A.

Description	Factory Installed Flange Control ① Position 9 Cover Control Code	Field Installation Kits Catalog Number
Non-Reversing		
No cover mounted pilot devices	A	C400GK0
STOP/START pushbuttons	B	C400GK1
With red RUN pilot light	C	C400GK12 ②
With red RUN/green OFF lights	D	C400GK16 ②
HAND/OFF/AUTO selector switch	H	C400GK3
With red RUN pilot light	J	C400GK32 ②
With red RUN/green OFF lights	K	C400GK36 ②
Red RUN pilot light	P	C400GK42 ②
Green OFF pilot light	Q	C400GK41 ②
Red RUN/green OFF pilot lights	R	C400GK46 ②
Reversing		
No cover mounted pilot devices	A	C400GK0
FOR/REV/STOP pushbuttons	B	C400GR1
With two red pilot lights	C	C400GR14 ②
UP/STOP/DOWN pushbuttons	E	C400GR2
With two red pilot lights	F	C400GR24 ②
Two red pilot lights	P	C400GK44 ②
One green pilot light	Q	C400GK41 ②

Notes

- ① For more available factory installed flange control, see **Page V10-T3-11**.
 ② Add code letter from the table below to catalog number for voltage—kits only. Example: C400GK0B.

Rating	Code Letter	Rating	Code Letter	Rating	Code Letter
120 V 60 Hz	A	277 V 60 Hz	H	480 V 60 Hz	C
208 V 60 Hz	E	380 V 50 Hz	L	600 V 60 Hz	D
240 V 60 Hz	B				

Type 1 Non-Combination Empty Enclosure (Box 1 Only)

There is a universal empty enclosure for the non-metallic Type 1 Non-Combination Box 1 regardless of the starter or the contactor needed. The only difference is the length of the easily interchangeable reset rod. The reset rod kit provides everything needed to install the correct reset rod, including all the reset rod lengths, a protective shroud, a paddle and a reset button with nut.

Box 1 offering includes metallic enclosures with starters up to 32 A.

Empty Enclosure Stacking Needs	Catalog Number
Empty enclosure	C899001
Reset rod kit	RESET001

The table below shows which reset rod is used with each starter or contactor.

Starter or Contactor	Reset Rod Length
IEC Frame Size B and C, SSOL	0.74-inch reset
IEC Frame Size B, Bi-Metallic Overload	1.74-inch reset
IEC Frame Size C, Bi-Metallic Overload	1.30-inch reset

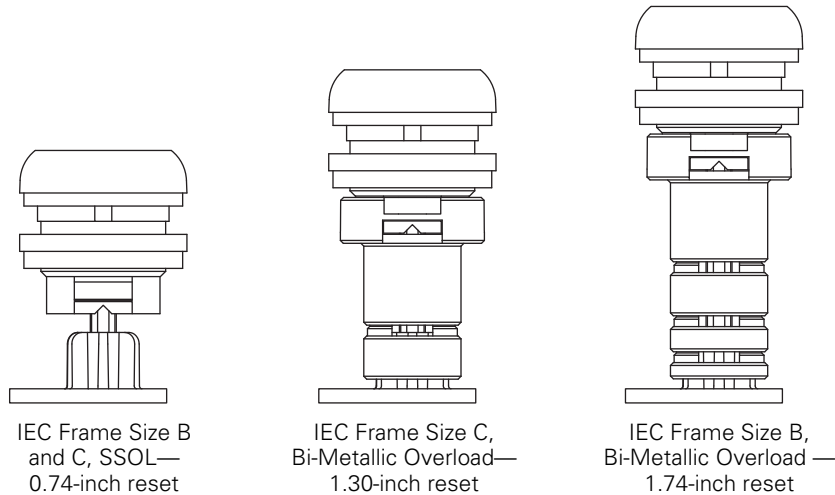

Product Selection

Non-Combination Starters

Class ECX09—Non-Combination Non-Reversing Starter

3

Amps	Maximum hp ^①			Coil Voltage at 60 Hz ^③	Type 1/IP23	Type 4X/IP66 ^⑤	Type 12/IP65	Component
	Motor Voltage ^②	Single-Phase	Three-Phase		Catalog Number ^④	Catalog Number ^④	Catalog Number ^④	Catalog Number ^④
Size B								
7	115	1/4	—	120	ECX09B1AAA- ₋	ECX09B4AAA- ₋	ECX09B8AAA- ₋	XTAE007B10A ₋
	208	3/4	1-1/2	208	ECX09B1EAA- ₋	ECX09B4EAA- ₋	ECX09B8EAA- ₋	XTAE007B10E ₋
	230	1	2	240	ECX09B1BAA- ₋	ECX09B4BAA- ₋	ECX09B8BAA- ₋	XTAE007B10B ₋
	380	—	3	380/50 Hz	ECX09B1LAA- ₋	ECX09B4LAA- ₋	ECX09B8LAA- ₋	XTAE007B10L ₋
	460	—	3	480	ECX09B1CAA- ₋	ECX09B4CAA- ₋	ECX09B8CAA- ₋	XTAE007B10C ₋
	575	—	5	600	ECX09B1DAA- ₋	ECX09B4DAA- ₋	ECX09B8DAA- ₋	XTAE007B10D ₋
Size C								
9	115	1/2	—	120	ECX09C1AAA- ₋	ECX09C4AAA- ₋	ECX09C8AAA- ₋	XTAE009B10A ₋
	208	1	2	208	ECX09C1EAA- ₋	ECX09C4EAA- ₋	ECX09C8EAA- ₋	XTAE009B10E ₋
	230	1-1/2	3	240	ECX09C1BAA- ₋	ECX09C4BAA- ₋	ECX09C8BAA- ₋	XTAE009B10B ₋
	380	—	5	380/50 Hz	ECX09C1LAA- ₋	ECX09C4LAA- ₋	ECX09C8LAA- ₋	XTAE009B10L ₋
	460	—	5	480	ECX09C1CAA- ₋	ECX09C4CAA- ₋	ECX09C8CAA- ₋	XTAE009B10C ₋
	575	—	7-1/2	600	ECX09C1DAA- ₋	ECX09C4DAA- ₋	ECX09C8DAA- ₋	XTAE009B10D ₋
Size D								
12	115	1/2	—	120	ECX09D1AAA- ₋	ECX09D4AAA- ₋	ECX09D8AAA- ₋	XTAE012B10A ₋
	208	1-1/2	3	208	ECX09D1EAA- ₋	ECX09D4EAA- ₋	ECX09D8EAA- ₋	XTAE012B10E ₋
	230	2	3	240	ECX09D1BAA- ₋	ECX09D4BAA- ₋	ECX09D8BAA- ₋	XTAE012B10B ₋
	380	—	5	380/50 Hz	ECX09D1LAA- ₋	ECX09D4LAA- ₋	ECX09D8LAA- ₋	XTAE012B10L ₋
	460	—	7-1/2	480	ECX09D1CAA- ₋	ECX09D4CAA- ₋	ECX09D8CAA- ₋	XTAE012B10C ₋
	575	—	10	600	ECX09D1DAA- ₋	ECX09D4DAA- ₋	ECX09D8DAA- ₋	XTAE012B10D ₋
Size E								
15	115	3/4	—	120	ECX09E1AAA- ₋	ECX09E4AAA- ₋	ECX09E8AAA- ₋	XTAE015B10A ₋
	208	2	3	208	ECX09E1EAA- ₋	ECX09E4EAA- ₋	ECX09E8EAA- ₋	XTAE015B10E ₋
	230	2	3	240	ECX09E1BAA- ₋	ECX09E4BAA- ₋	ECX09E8BAA- ₋	XTAE015B10B ₋
	380	—	5	380/50 Hz	ECX09E1LAA- ₋	ECX09E4LAA- ₋	ECX09E8LAA- ₋	XTAE015B10L ₋
	460	—	7-1/2	480	ECX09E1CAA- ₋	ECX09E4CAA- ₋	ECX09E8CAA- ₋	XTAE015B10C ₋
	575	—	10	600	ECX09E1DAA- ₋	ECX09E4DAA- ₋	ECX09E8DAA- ₋	XTAE015B10D ₋
Size F								
18	115	2	—	120	ECX09F1AAA- ₋	ECX09F4AAA- ₋	ECX09F8AAA- ₋	XTAE018C10A ₋
	208	2	5	208	ECX09F1EAA- ₋	ECX09F4EAA- ₋	ECX09F8EAA- ₋	XTAE018C10E ₋
	230	3	5	240	ECX09F1BAA- ₋	ECX09F4BAA- ₋	ECX09F8BAA- ₋	XTAE018C10B ₋
	380	—	7-1/2	380/50 Hz	ECX09F1LAA- ₋	ECX09F4LAA- ₋	ECX09F8LAA- ₋	XTAE018C10L ₋
	460	—	10	480	ECX09F1CAA- ₋	ECX09F4CAA- ₋	ECX09F8CAA- ₋	XTAE018C10C ₋
	575	—	15	600	ECX09F1DAA- ₋	ECX09F4DAA- ₋	ECX09F8DAA- ₋	XTAE018C10D ₋

Notes

- ① 1 hp = 0.746 kW.
- ② Contact factory for other voltage options.
- ③ Voltage is listed at 60 Hz unless otherwise noted. Other voltages available upon request.
- ④ Select proper "XTOB" overload amperage range as per motor FLA, see **Page V10-T3-9**.
- ⑤ The catalog numbers listed in the Type 4X column are for Type 4X 304-Grade stainless steel, as indicated by the **seventh** digit.
 Example: ECX09B4AAA-₋. To order Type 4X 316-Grade stainless steel, change that digit to **9**. To order Type 4 painted steel, change that digit to **3**.
 To order non-metallic, change that digit to **5**. For details on these alternate enclosures, see **Tab 13**.

Class ECX09—Non-Combination Non-Reversing Starter, continued

Amps	Maximum hp ^①		Coil Voltage at 60 Hz ^③	Type 1/IP23	Type 4X/IP66 ^⑥	Type 12/IP65	Component	
	Motor Voltage ^②	Single-Phase		Three-Phase	Catalog Number ^④	Catalog Number ^④		Catalog Number ^④
Size G								
25	115	2	—	120	ECX09G1AAA- __	ECX09G4AAA- __	ECX09G8AAA- __	XTAE025C10A- __
	208	3	7-1/2	208	ECX09G1EAA- __	ECX09G4EAA- __	ECX09G8EAA- __	XTAE025C10E- __
	230	5	7-1/2	240	ECX09G1BAA- __	ECX09G4BAA- __	ECX09G8BAA- __	XTAE025C10B- __
	380	—	10	380/50 Hz	ECX09G1LAA- __	ECX09G4LAA- __	ECX09G8LAA- __	XTAE025C10L- __
	460	—	15	480	ECX09G1CAA- __	ECX09G4CAA- __	ECX09G8CAA- __	XTAE025C10C- __
	575	—	20	600	ECX09G1DAA- __	ECX09G4DAA- __	ECX09G8DAA- __	XTAE025C10D- __
Size H								
32	115	3	—	120	ECX09H1AAA- __	ECX09H4AAA- __	ECX09H8AAA- __	XTAE032C10A- __
	208	5	10	208	ECX09H1EAA- __	ECX09H4EAA- __	ECX09H8EAA- __	XTAE032C10E- __
	230	5	10	240	ECX09H1BAA- __	ECX09H4BAA- __	ECX09H8BAA- __	XTAE032C10B- __
	380	—	15	380/50 Hz	ECX09H1LAA- __	ECX09H4LAA- __	ECX09H8LAA- __	XTAE032C10L- __
	460	—	20	480	ECX09H1CAA- __	ECX09H4CAA- __	ECX09H8CAA- __	XTAE032C10C- __
	575	—	25	600	ECX09H1DAA- __	ECX09H4DAA- __	ECX09H8DAA- __	XTAE032C10D- __
Size J								
40	115	3	—	120	ECX09J1AAA- __	ECX09J4AAA- __	ECX09J8AAA- __	XTAE040D00A- __
	208	5	10	208	ECX09J1EAA- __	ECX09J4EAA- __	ECX09J8EAA- __	XTAE040D00E- __
	230	7-1/2	15	240	ECX09J1BAA- __	ECX09J4BAA- __	ECX09J8BAA- __	XTAE040D00D- __
	380	—	15	380/50 Hz	ECX09J1LAA- __	ECX09J4LAA- __	ECX09J8LAA- __	XTAE040D00L- __
	460	—	30	480	ECX09J1CAA- __	ECX09J4CAA- __	ECX09J8CAA- __	XTAE040D00C- __
	575	—	40	600	ECX09J1DAA- __	ECX09J4DAA- __	ECX09J8DAA- __	XTAE040D00D- __
Size K								
50	115	3	—	120	ECX09K1AAA- __	ECX09K4AAA- __	ECX09K8AAA- __	XTAE050D00A- __
	208	7-1/2	15	208	ECX09K1EAA- __	ECX09K4EAA- __	ECX09K8EAA- __	XTAE050D00E- __
	230	10	20	240	ECX09K1BAA- __	ECX09K4BAA- __	ECX09K8BAA- __	XTAE050D00B- __
	380	—	20	380/50 Hz	ECX09K1LAA- __	ECX09K4LAA- __	ECX09K8LAA- __	XTAE050D00L- __
	460	—	40	480	ECX09K1CAA- __	ECX09K4CAA- __	ECX09K8CAA- __	XTAE050D00C- __
	575	—	50	600	ECX09K1DAA- __	ECX09K4DAA- __	ECX09K8DAA- __	XTAE050D00D- __
Size L								
65	115	5	—	120	ECX09L1AAA- __	ECX09L4AAA- __	ECX09L8AAA- __	XTAE065D00A- __
	208	10	20	208	ECX09L1EAA- __	ECX09L4EAA- __	ECX09L8EAA- __	XTAE065D00E- __
	230	15	25	240	ECX09L1BAA- __	ECX09L4BAA- __	ECX09L8BAA- __	XTAE065D00B- __
	380	—	30	380/50 Hz	ECX09L1LAA- __	ECX09L4LAA- __	ECX09L8LAA- __	XTAE065D00L- __
	460	—	50	480	ECX09L1CAA- __	ECX09L4CAA- __	ECX09L8CAA- __	XTAE065D00C- __
	575	—	60	600	ECX09L1DAA- __	ECX09L4DAA- __	ECX09L8DAA- __	XTAE065D00D- __

Notes

- ① 1 hp = 0.746 kW.
 ② Contact factory for other voltage options.
 ③ Voltage is listed at 60 Hz unless otherwise noted. Other voltages available upon request.
 ④ Select proper "XTOB" overload amperage range as per motor FLA, see **Page V10-T3-9**.
 ⑥ The catalog numbers listed in the Type 4X column are for Type 4X 304-Grade stainless steel, as indicated by the **seventh** digit.
 Example: ECX09G4AAA-_{_}. To order Type 4X 316-Grade stainless steel, change that digit to **9**. To order Type 4 painted steel, change that digit to **3**.
 To order non-metallic, change that digit to **5**. For details on these alternate enclosures, see **Tab 13**.

3.1

IEC Contactors and Starters

XT IEC Power Control

3

Class ECX09—Non-Combination Non-Reversing Starter, continued

Amps	Maximum hp ^①		Coil Voltage at 60 Hz ^③	Type 1/IP23	Type 4X/IP66 ^⑥	Type 12/IP65	Component	
	Motor Voltage ^②	Single-Phase		Three-Phase	Catalog Number ^④	Catalog Number ^④	Catalog Number ^④	Catalog Number ^④
Size M								
80	115	7-1/2	—	120	ECX09M1AAA- __	ECX09M4AAA- __	ECX09M8AAA- __	XTAE080F00A- __
	208	15	25	208	ECX09M1EAA- __	ECX09M4EAA- __	ECX09M8EAA- __	XTAE080F00E- __
	230	15	30	240	ECX09M1BAA- __	ECX09M4BAA- __	ECX09M8BAA- __	XTAE080F00B- __
	380	—	50	380/50 Hz	ECX09M1LAA- __	ECX09M4LAA- __	ECX09M8LAA- __	XTAE080F00L- __
	460	—	60	480	ECX09M1CAA- __	ECX09M4CAA- __	ECX09M8CAA- __	XTAE080F00C- __
	575	—	75	600	ECX09M1DAA- __	ECX09M4DAA- __	ECX09M8DAA- __	XTAE080F00D- __
Size N								
95	115	7-1/2	—	120	ECX09N1AAA- __	ECX09N4AAA- __	ECX09N8AAA- __	XTAE095F00A- __
	208	15	25	208	ECX09N1EAA- __	ECX09N4EAA- __	ECX09N8EAA- __	XTAE095F00E- __
	230	15	40	240	ECX09N1BAA- __	ECX09N4BAA- __	ECX09N8BAA- __	XTAE095F00B- __
	380	—	60	380/50 Hz	ECX09N1LAA- __	ECX09N4LAA- __	ECX09N8LAA- __	XTAE095F00L- __
	460	—	75	480	ECX09N1CAA- __	ECX09N4CAA- __	ECX09N8CAA- __	XTAE095F00C- __
	575	—	100	600	ECX09N1DAA- __	ECX09N4DAA- __	ECX09N8DAA- __	XTAE095F00D- __
Size P								
115	115	10	—	120	ECX09P1AAA- __	ECX09P4AAA- __	ECX09P8AAA- __	XTAE115G00A- __
	208	25	40	208	ECX09P1EAA- __	ECX09P4EAA- __	ECX09P8EAA- __	XTAE115G00E- __
	230	25	50	240	ECX09P1BAA- __	ECX09P4BAA- __	ECX09P8BAA- __	XTAE115G00B- __
	380	—	60	380/50 Hz	ECX09P1LAA- __	ECX09P4LAA- __	ECX09P8LAA- __	XTAE115G00L- __
	460	—	100	480	ECX09P1CAA- __	ECX09P4CAA- __	ECX09P8CAA- __	XTAE115G00C- __
	575	—	125	600	ECX09P1DAA- __	ECX09P4DAA- __	ECX09P8DAA- __	XTAE115G00D- __
Size Q								
150	115	15	—	120	ECX09Q1AAA- __	ECX09Q4AAA- __	ECX09Q8AAA- __	XTAE150G00A- __
	208	25	40	208	ECX09Q1EAA- __	ECX09Q4EAA- __	ECX09Q8EAA- __	XTAE150G00E- __
	230	30	60	240	ECX09Q1BAA- __	ECX09Q4BAA- __	ECX09Q8BAA- __	XTAE150G00B- __
	380	—	60	380/50 Hz	ECX09Q1LAA- __	ECX09Q4LAA- __	ECX09Q8LAA- __	XTAE150G00L- __
	460	—	125	480	ECX09Q1CAA- __	ECX09Q4CAA- __	ECX09Q8CAA- __	XTAE150G00C- __
	575	—	150	600	ECX09Q1DAA- __	ECX09Q4DAA- __	ECX09Q8DAA- __	XTAE150G00D- __

Notes

- ① 1 hp = 0.746 kW.
- ② Contact factory for other voltage options.
- ③ Voltage is listed at 60 Hz unless otherwise noted. Other voltages available upon request.
- ④ Select proper "XTOB" overload amperage range as per motor FLA, see **Page V10-T3-9**.
- ⑥ The catalog numbers listed in the Type 4X column are for Type 4X 304-Grade stainless steel, as indicated by the **seventh** digit.
Example: ECX09M4AAA-_{_}. To order Type 4X 316-Grade stainless steel, change that digit to **9**. To order Type 4 painted steel, change that digit to **3**. To order non-metallic, change that digit to **5**. For details on these alternate enclosures, see **Tab 13**.

Class ECX10—Non-Combination Reversing Starter

Amps	Maximum hp ^①		Coil Voltage at 60 Hz ^③	Type 1/IP23	Type 4X/IP66 ^⑥	Type 12/IP65	Component	
	Motor Voltage ^②	Single-Phase		Three-Phase	Catalog Number ^④	Catalog Number ^④		Catalog Number ^④
Size B								
7	115	1/4	—	120	ECX10B1AAA- ₋	ECX10B4AAA- ₋	ECX10B8AAA- ₋	XTAR007B10A- ₋
	208	3/4	1-1/2	208	ECX10B1EAA- ₋	ECX10B4EAA- ₋	ECX10B8EAA- ₋	XTAR007B10E- ₋
	230	1	2	240	ECX10B1BAA- ₋	ECX10B4BAA- ₋	ECX10B8BAA- ₋	XTAR007B10B- ₋
	380	—	3	380/50 Hz	ECX10B1LAA- ₋	ECX10B4LAA- ₋	ECX10B8LAA- ₋	XTAR007B10L- ₋
	460	—	3	480	ECX10B1CAA- ₋	ECX10B4CAA- ₋	ECX10B8CAA- ₋	XTAR007B10C- ₋
	575	—	5	600	ECX10B1DAA- ₋	ECX10B4DAA- ₋	ECX10B8DAA- ₋	XTAR007B10D- ₋
Size C								
9	115	1/2	—	120	ECX10C1AAA- ₋	ECX10C4AAA- ₋	ECX10C8AAA- ₋	XTAR009B10A- ₋
	208	1	2	208	ECX10C1EAA- ₋	ECX10C4EAA- ₋	ECX10C8EAA- ₋	XTAR009B10E- ₋
	230	1-1/2	3	240	ECX10C1BAA- ₋	ECX10C4BAA- ₋	ECX10C8BAA- ₋	XTAR009B10B- ₋
	380	—	5	380/50 Hz	ECX10C1LAA- ₋	ECX10C4LAA- ₋	ECX10C8LAA- ₋	XTAR009B10L- ₋
	460	—	5	480	ECX10C1CAA- ₋	ECX10C4CAA- ₋	ECX10C8CAA- ₋	XTAR009B10C- ₋
	575	—	7-1/2	600	ECX10C1DAA- ₋	ECX10C4DAA- ₋	ECX10C8DAA- ₋	XTAR009B10D- ₋
Size D								
12	115	1/2	—	120	ECX10D1AAA- ₋	ECX10D4AAA- ₋	ECX10D8AAA- ₋	XTAR012B10A- ₋
	208	1-1/2	3	208	ECX10D1EAA- ₋	ECX10D4EAA- ₋	ECX10D8EAA- ₋	XTAR012B10E- ₋
	230	2	3	240	ECX10D1BAA- ₋	ECX10D4BAA- ₋	ECX10D8BAA- ₋	XTAR012B10B- ₋
	380	—	5	380/50 Hz	ECX10D1LAA- ₋	ECX10D4LAA- ₋	ECX10D8LAA- ₋	XTAR012B10L- ₋
	460	—	7-1/2	480	ECX10D1CAA- ₋	ECX10D4CAA- ₋	ECX10D8CAA- ₋	XTAR012B10C- ₋
	575	—	10	600	ECX10D1DAA- ₋	ECX10D4DAA- ₋	ECX10D8DAA- ₋	XTAR012B10D- ₋
Size E								
15	115	3/4	—	120	ECX10E1AAA- ₋	ECX10E4AAA- ₋	ECX10E8AAA- ₋	XTAR015B10A- ₋
	208	2	3	208	ECX10E1EAA- ₋	ECX10E4EAA- ₋	ECX10E8EAA- ₋	XTAR015B10E- ₋
	230	2	3	240	ECX10E1BAA- ₋	ECX10E4BAA- ₋	ECX10E8BAA- ₋	XTAR015B10B- ₋
	380	—	5	380/50 Hz	ECX10E1LAA- ₋	ECX10E4LAA- ₋	ECX10E8LAA- ₋	XTAR015B10L- ₋
	460	—	7-1/2	480	ECX10E1CAA- ₋	ECX10E4CAA- ₋	ECX10E8CAA- ₋	XTAR015B10C- ₋
	575	—	10	600	ECX10E1DAA- ₋	ECX10E4DAA- ₋	ECX10E8DAA- ₋	XTAR015B10D- ₋
Size F								
18	115	2	—	120	ECX10F1AAA- ₋	ECX10F4AAA- ₋	ECX10F8AAA- ₋	XTAR018C10A- ₋
	208	2	5	208	ECX10F1EAA- ₋	ECX10F4EAA- ₋	ECX10F8EAA- ₋	XTAR018C10E- ₋
	230	3	5	240	ECX10F1BAA- ₋	ECX10F4BAA- ₋	ECX10F8BAA- ₋	XTAR018C10B- ₋
	380	—	7-1/2	380/50 Hz	ECX10F1LAA- ₋	ECX10F4LAA- ₋	ECX10F8LAA- ₋	XTAR018C10L- ₋
	460	—	10	480	ECX10F1CAA- ₋	ECX10F4CAA- ₋	ECX10F8CAA- ₋	XTAR018C10C- ₋
	575	—	15	600	ECX10F1DAA- ₋	ECX10F4DAA- ₋	ECX10F8DAA- ₋	XTAR018C10D- ₋

Notes

① 1 hp = 0.746 kW.

② Contact factory for other voltage options.

③ Voltage is listed at 60 Hz unless otherwise noted. Other voltages available upon request.

④ Select proper "XTOB" overload amperage range as per motor FLA, see **Page V10-T3-9**.

⑥ The catalog numbers listed in the Type 4X column are for Type 4X 304-Grade stainless steel, as indicated by the **seventh** digit.

Example: ECX10B4AAA-₋. To order Type 4X 316-Grade stainless steel, change that digit to **9**. To order Type 4 painted steel, change that digit to **3**.

To order non-metallic, change that digit to **5**. For details on these alternate enclosures, see **Tab 13**.

3.1

IEC Contactors and Starters

XT IEC Power Control

3

Class ECX10—Non-Combination Reversing Starter, continued

Amps	Maximum hp ^①		Coil Voltage at 60 Hz ^③	Type 1/IP23	Type 4X/IP66 ^⑥	Type 12/IP65	Component	
	Motor Voltage ^②	Single-Phase		Three-Phase	Catalog Number ^④	Catalog Number ^④	Catalog Number ^④	Catalog Number ^④
Size G								
25	115	2	—	120	ECX10G1AAA-	ECX10G4AAA-	ECX10G8AAA-	XTAR025C10A
	208	3	7-1/2	208	ECX10G1EAA-	ECX10G4EAA-	ECX10G8EAA-	XTAR025C10E
	230	5	7-1/2	240	ECX10G1BAA-	ECX10G4BAA-	ECX10G8BAA-	XTAR025C10B
	380	—	10	380/50 Hz	ECX10G1LAA-	ECX10G4LAA-	ECX10G8LAA-	XTAR025C10L
	460	—	15	480	ECX10G1CAA-	ECX10G4CAA-	ECX10G8CAA-	XTAR025C10C
	575	—	20	600	ECX10G1DAA-	ECX10G4DAA-	ECX10G8DAA-	XTAR025C10D
	Size H							
32	115	3	—	120	ECX10H1AAA-	ECX10H4AAA-	ECX10H8AAA-	XTAR032C10A
	208	5	10	208	ECX10H1EAA-	ECX10H4EAA-	ECX10H8EAA-	XTAR032C10E
	230	5	10	240	ECX10H1BAA-	ECX10H4BAA-	ECX10H8BAA-	XTAR032C10B
	380	—	15	380/50 Hz	ECX10H1LAA-	ECX10H4LAA-	ECX10H8LAA-	XTAR032C10L
	460	—	20	480	ECX10H1CAA-	ECX10H4CAA-	ECX10H8CAA-	XTAR032C10C
	575	—	25	600	ECX10H1DAA-	ECX10H4DAA-	ECX10H8DAA-	XTAR032C10D
	Size J							
40	115	3	—	120	ECX10J1AAA-	ECX10J4AAA-	ECX10J8AAA-	XTAR040D00A
	208	5	10	208	ECX10J1EAA-	ECX10J4EAA-	ECX10J8EAA-	XTAR040D00E
	230	7-1/2	15	240	ECX10J1BAA-	ECX10J4BAA-	ECX10J8BAA-	XTAR040D00B
	380	—	15	380/50 Hz	ECX10J1LAA-	ECX10J4LAA-	ECX10J8LAA-	XTAR040D00L
	460	—	30	480	ECX10J1CAA-	ECX10J4CAA-	ECX10J8CAA-	XTAR040D00C
	575	—	40	600	ECX10J1DAA-	ECX10J4DAA-	ECX10J8DAA-	XTAR040D00D
	Size K							
50	115	3	—	120	ECX10K1AAA-	ECX10K4AAA-	ECX10K8AAA-	XTAR050D00A
	208	7-1/2	15	208	ECX10K1EAA-	ECX10K4EAA-	ECX10K8EAA-	XTAR050D00E
	230	10	20	240	ECX10K1BAA-	ECX10K4BAA-	ECX10K8BAA-	XTAR050D00B
	380	—	20	380/50 Hz	ECX10K1LAA-	ECX10K4LAA-	ECX10K8LAA-	XTAR050D00L
	460	—	40	480	ECX10K1CAA-	ECX10K4CAA-	ECX10K8CAA-	XTAR050D00C
	575	—	50	600	ECX10K1DAA-	ECX10K4DAA-	ECX10K8DAA-	XTAR050D00D
	Size L							
65	115	5	—	120	ECX10L1AAA-	ECX10L4AAA-	ECX10L8AAA-	XTAR065D00A
	208	10	20	208	ECX10L1EAA-	ECX10L4EAA-	ECX10L8EAA-	XTAR065D00E
	230	15	25	240	ECX10L1BAA-	ECX10L4BAA-	ECX10L8BAA-	XTAR065D00B
	380	—	30	380/50 Hz	ECX10L1LAA-	ECX10L4LAA-	ECX10L8LAA-	XTAR065D00L
	460	—	50	480	ECX10L1CAA-	ECX10L4CAA-	ECX10L8CAA-	XTAR065D00C
	575	—	60	600	ECX10L1DAA-	ECX10L4DAA-	ECX10L8DAA-	XTAR065D00D

Notes

- ① 1 hp = 0.746 kW.
- ② Contact factory for other voltage options.
- ③ Voltage is listed at 60 Hz unless otherwise noted. Other voltages available upon request.
- ④ Select proper "XTOB" overload amperage range as per motor FLA, see **Page V10-T3-9**.
- ⑥ The catalog numbers listed in the Type 4X column are for Type 4X 304-Grade stainless steel, as indicated by the **seventh** digit.
Example: ECX10G4AAA-_. To order Type 4X 316-Grade stainless steel, change that digit to **9**. To order Type 4 painted steel, change that digit to **3**. To order non-metallic, change that digit to **5**. For details on these alternate enclosures, see **Tab 13**.

Class ECX10—Non-Combination Reversing Starter, continued

Amps	Maximum hp ^①		Coil Voltage at 60 Hz ^③	Type 1/IP23	Type 4X/IP66 ^⑥	Type 12/IP65	Component	
	Motor Voltage ^②	Single-Phase		Three-Phase	Catalog Number ^④	Catalog Number ^④	Catalog Number ^④	Catalog Number ^④
Size M								
80	115	7-1/2	—	120	ECX10M1AAA-	ECX10M4AAA-	ECX10M8AAA-	XTAR080F00A-
	208	15	25	208	ECX10M1EAA-	ECX10M4EAA-	ECX10M8EAA-	XTAR080F00E-
	230	15	30	240	ECX10M1BAA-	ECX10M4BAA-	ECX10M8BAA-	XTAR080F00B-
	380	—	50	380/50 Hz	ECX10M1LAA-	ECX10M4LAA-	ECX10M8LAA-	XTAR080F00L-
	460	—	60	480	ECX10M1CAA-	ECX10M4CAA-	ECX10M8CAA-	XTAR080F00C-
	575	—	75	600	ECX10M1DAA-	ECX10M4DAA-	ECX10M8DAA-	XTAR080F00D-
Size N								
95	115	7-1/2	—	120	ECX10N1AAA-	ECX10N4AAA-	ECX10N8AAA-	XTAR095F00A-
	208	15	25	208	ECX10N1EAA-	ECX10N4EAA-	ECX10N8EAA-	XTAR095F00E-
	230	15	40	240	ECX10N1BAA-	ECX10N4BAA-	ECX10N8BAA-	XTAR095F00B-
	380	—	60	380/50 Hz	ECX10N1LAA-	ECX10N4LAA-	ECX10N8LAA-	XTAR095F00L-
	460	—	75	480	ECX10N1CAA-	ECX10N4CAA-	ECX10N8CAA-	XTAR095F00C-
	575	—	100	600	ECX10N1DAA-	ECX10N4DAA-	ECX10N8DAA-	XTAR095F00D-
Size P								
115	115	10	—	120	ECX10P1AAA-	ECX10P4AAA-	ECX10P8AAA-	XTAR115G00A-
	208	25	40	208	ECX10P1EAA-	ECX10P4EAA-	ECX10P8EAA-	XTAR115G00E-
	230	25	50	240	ECX10P1BAA-	ECX10P4BAA-	ECX10P8BAA-	XTAR115G00B-
	380	—	60	380/50 Hz	ECX10P1LAA-	ECX10P4LAA-	ECX10P8LAA-	XTAR115G00L-
	460	—	100	480	ECX10P1CAA-	ECX10P4CAA-	ECX10P8CAA-	XTAR115G00C-
	575	—	125	600	ECX10P1DAA-	ECX10P4DAA-	ECX10P8DAA-	XTAR115G00D-
Size Q								
150	115	15	—	120	ECX10Q1AAA-	ECX10Q4AAA-	ECX10Q8AAA-	XTAR150G00A-
	208	25	40	208	ECX10Q1EAA-	ECX10Q4EAA-	ECX10Q8EAA-	XTAR150G00E-
	230	30	60	240	ECX10Q1BAA-	ECX10Q4BAA-	ECX10Q8BAA-	XTAR150G00B-
	380	—	60	380/50 Hz	ECX10Q1LAA-	ECX10Q4LAA-	ECX10Q8LAA-	XTAR150G00L-
	460	—	125	480	ECX10Q1CAA-	ECX10Q4CAA-	ECX10Q8CAA-	XTAR150G00C-
	575	—	150	600	ECX10Q1DAA-	ECX10Q4DAA-	ECX10Q8DAA-	XTAR150G00D-

Notes

- ① 1 hp = 0.746 kW.
 ② Contact factory for other voltage options.
 ③ Voltage is listed at 60 Hz unless otherwise noted. Other voltages available upon request.
 ④ Select proper "XTOB" overload amperage range as per motor FLA, see **Page V10-T3-9**.
 ⑤ The catalog numbers listed in the Type 4X column are for Type 4X 304-Grade stainless steel, as indicated by the **seventh** digit.
 Example: ECX10M4AAA-. To order Type 4X 316-Grade stainless steel, change that digit to **9**. To order Type 4 painted steel, change that digit to **3**.
 To order non-metallic, change that digit to **5**. For details on these alternate enclosures, see **Tab 13**.

3.1

IEC Contactors and Starters

X7 IEC Power Control

3

Class ECX11—Non-Combination Non-Reversing Starter with CPT

Amps	Maximum hp ^①		Coil Voltage at 60 Hz ^③	Type 1/IP23	Type 4X/IP66 ^⑥	Type 12/IP65	Component	
	Motor Voltage ^②	Single-Phase		Three-Phase	Catalog Number ^④	Catalog Number ^④	Catalog Number ^④	Catalog Number ^④
Size B								
7	115	1/4	—	120	ECX11B1AAA-	ECX11B4AAA-	ECX11B8AAA-	XTAE007B10A
	208	3/4	1-1/2	120	ECX11B1AAA-	ECX11B4AAA-	ECX11B8AAA-	XTAE007B10A
	230	1	2	120	ECX11B1AAA-	ECX11B4AAA-	ECX11B8AAA-	XTAE007B10A
	380	—	3	110	ECX11B1AAA-	ECX11B4AAA-	ECX11B8AAA-	XTAE007B10A
	460	—	3	120	ECX11B1AAA-	ECX11B4AAA-	ECX11B8AAA-	XTAE007B10A
	575	—	5	120	ECX11B1AAA-	ECX11B4AAA-	ECX11B8AAA-	XTAE007B10A
Size C								
9	115	1/2	—	120	ECX11C1AAA-	ECX11C4AAA-	ECX11C8AAA-	XTAE009B10A
	208	1	2	120	ECX11C1AAA-	ECX11C4AAA-	ECX11C8AAA-	XTAE009B10A
	230	1-1/2	3	120	ECX11C1AAA-	ECX11C4AAA-	ECX11C8AAA-	XTAE009B10A
	380	—	5	110	ECX11C1AAA-	ECX11C4AAA-	ECX11C8AAA-	XTAE009B10A
	460	—	5	120	ECX11C1AAA-	ECX11C4AAA-	ECX11C8AAA-	XTAE009B10A
	575	—	7-1/2	120	ECX11C1AAA-	ECX11C4AAA-	ECX11C8AAA-	XTAE009B10A
Size D								
12	115	1/2	—	120	ECX11D1AAA-	ECX11D4AAA-	ECX11D8AAA-	XTAE012B10A
	208	1-1/2	3	120	ECX11D1AAA-	ECX11D4AAA-	ECX11D8AAA-	XTAE012B10A
	230	2	3	120	ECX11D1AAA-	ECX11D4AAA-	ECX11D8AAA-	XTAE012B10A
	380	—	5	110	ECX11D1AAA-	ECX11D4AAA-	ECX11D8AAA-	XTAE012B10A
	460	—	7-1/2	120	ECX11D1AAA-	ECX11D4AAA-	ECX11D8AAA-	XTAE012B10A
	575	—	10	120	ECX11D1AAA-	ECX11D4AAA-	ECX11D8AAA-	XTAE012B10A
Size E								
15	115	3/4	—	120	ECX11E1AAA-	ECX11E4AAA-	ECX11E8AAA-	XTAE015B10A
	208	2	3	120	ECX11E1AAA-	ECX11E4AAA-	ECX11E8AAA-	XTAE015B10A
	230	2	3	120	ECX11E1AAA-	ECX11E4AAA-	ECX11E8AAA-	XTAE015B10A
	380	—	5	110	ECX11E1AAA-	ECX11E4AAA-	ECX11E8AAA-	XTAE015B10A
	460	—	7-1/2	120	ECX11E1AAA-	ECX11E4AAA-	ECX11E8AAA-	XTAE015B10A
	575	—	10	120	ECX11E1AAA-	ECX11E4AAA-	ECX11E8AAA-	XTAE015B10A
Size F								
18	115	2	—	120	ECX11F1AAA-	ECX11F4AAA-	ECX11F8AAA-	XTAE018C10A
	208	2	5	120	ECX11F1AAA-	ECX11F4AAA-	ECX11F8AAA-	XTAE018C10A
	230	3	5	120	ECX11F1AAA-	ECX11F4AAA-	ECX11F8AAA-	XTAE018C10A
	380	—	7-1/2	110	ECX11F1AAA-	ECX11F4AAA-	ECX11F8AAA-	XTAE018C10A
	460	—	10	120	ECX11F1AAA-	ECX11F4AAA-	ECX11F8AAA-	XTAE018C10A
	575	—	15	120	ECX11F1AAA-	ECX11F4AAA-	ECX11F8AAA-	XTAE018C10A

Notes

- ① 1 hp = 0.746 kW.
- ② Contact factory for other voltage options.
- ③ Voltage is listed at 60 Hz unless otherwise noted. Other voltages available upon request.
- ④ Select proper "XTOB" overload amperage range as per motor FLA, see **Page V10-T3-9**.
- ⑥ The catalog numbers listed in the Type 4X column are for Type 4X 304-Grade stainless steel, as indicated by the **seventh** digit.
Example: ECX11B4AAA-_. To order Type 4X 316-Grade stainless steel, change that digit to **9**. To order Type 4 painted steel, change that digit to **3**. To order non-metallic, change that digit to **5**. For details on these alternate enclosures, see **Tab 13**.

Class ECX11—Non-Combination Non-Reversing Starter with CPT, continued

Amps	Maximum hp ^①		Coil Voltage at 60 Hz ^③	Type 1/IP23	Type 4X/IP66 ^⑥	Type 12/IP65	Component	
	Motor Voltage ^②	Single-Phase		Three-Phase	Catalog Number ^④	Catalog Number ^④	Catalog Number ^④	Catalog Number ^④
Size G								
25	115	2	—	120	ECX11G1AAA-	ECX11G4AAA-	ECX11G8AAA-	XTAE025C10A-
	208	3	7-1/2	120	ECX11G1AAA-	ECX11G4AAA-	ECX11G8AAA-	XTAE025C10A-
	230	5	7-1/2	120	ECX11G1AAA-	ECX11G4AAA-	ECX11G8AAA-	XTAE025C10A-
	380	—	10	110	ECX11G1AAA-	ECX11G4AAA-	ECX11G8AAA-	XTAE025C10A-
	460	—	15	120	ECX11G1AAA-	ECX11G4AAA-	ECX11G8AAA-	XTAE025C10A-
	575	—	20	120	ECX11G1AAA-	ECX11G4AAA-	ECX11G8AAA-	XTAE025C10A-
Size H								
32	115	3	—	120	ECX11H1AAA-	ECX11H4AAA-	ECX11H8AAA-	XTAE032C10A-
	208	5	10	120	ECX11H1AAA-	ECX11H4AAA-	ECX11H8AAA-	XTAE032C10A-
	230	5	10	120	ECX11H1AAA-	ECX11H4AAA-	ECX11H8AAA-	XTAE032C10A-
	380	—	15	110	ECX11H1AAA-	ECX11H4AAA-	ECX11H8AAA-	XTAE032C10A-
	460	—	20	120	ECX11H1AAA-	ECX11H4AAA-	ECX11H8AAA-	XTAE032C10A-
	575	—	25	120	ECX11H1AAA-	ECX11H4AAA-	ECX11H8AAA-	XTAE032C10A-
Size J								
40	115	3	—	120	ECX11J1AAA-	ECX11J4AAA-	ECX11J8AAA-	XTAE040D00A-
	208	5	10	120	ECX11J1AAA-	ECX11J4AAA-	ECX11J8AAA-	XTAE040D00A-
	230	7-1/2	15	120	ECX11J1AAA-	ECX11J4AAA-	ECX11J8AAA-	XTAE040D00A-
	380	—	15	110	ECX11J1AAA-	ECX11J4AAA-	ECX11J8AAA-	XTAE040D00A-
	460	—	30	120	ECX11J1AAA-	ECX11J4AAA-	ECX11J8AAA-	XTAE040D00A-
	575	—	40	120	ECX11J1AAA-	ECX11J4AAA-	ECX11J8AAA-	XTAE040D00A-
Size K								
50	115	3	—	120	ECX11K1AAA-	ECX11K4AAA-	ECX11K8AAA-	XTAE050D00A-
	208	7-1/2	15	120	ECX11K1AAA-	ECX11K4AAA-	ECX11K8AAA-	XTAE050D00A-
	230	10	20	120	ECX11K1AAA-	ECX11K4AAA-	ECX11K8AAA-	XTAE050D00A-
	380	—	20	110	ECX11K1AAA-	ECX11K4AAA-	ECX11K8AAA-	XTAE050D00A-
	460	—	40	120	ECX11K1AAA-	ECX11K4AAA-	ECX11K8AAA-	XTAE050D00A-
	575	—	50	120	ECX11K1AAA-	ECX11K4AAA-	ECX11K8AAA-	XTAE050D00A-
Size L								
65	115	5	—	120	ECX11L1AAA-	ECX11L4AAA-	ECX11L8AAA-	XTAE065D00A-
	208	10	20	120	ECX11L1AAA-	ECX11L4AAA-	ECX11L8AAA-	XTAE065D00A-
	230	15	25	120	ECX11L1AAA-	ECX11L4AAA-	ECX11L8AAA-	XTAE065D00A-
	380	—	30	110	ECX11L1AAA-	ECX11L4AAA-	ECX11L8AAA-	XTAE065D00A-
	460	—	50	120	ECX11L1AAA-	ECX11L4AAA-	ECX11L8AAA-	XTAE065D00A-
	575	—	60	120	ECX11L1AAA-	ECX11L4AAA-	ECX11L8AAA-	XTAE065D00A-

Notes

- ① 1 hp = 0.746 kW.
 ② Contact factory for other voltage options.
 ③ Voltage is listed at 60 Hz unless otherwise noted. Other voltages available upon request.
 ④ Select proper "XTOB" overload amperage range as per motor FLA, see **Page V10-T3-9**.
 ⑤ The catalog numbers listed in the Type 4X column are for Type 4X 304-Grade stainless steel, as indicated by the **seventh** digit.
 Example: ECX11G4AAA-. To order Type 4X 316-Grade stainless steel, change that digit to **9**. To order Type 4 painted steel, change that digit to **3**.
 To order non-metallic, change that digit to **5**. For details on these alternate enclosures, see **Tab 13**.

3.1

IEC Contactors and Starters

XT IEC Power Control

3

Class ECX11—Non-Combination Non-Reversing Starter with CPT, continued

Amps	Maximum hp ^①		Coil Voltage at 60 Hz ^③	Type 1/IP23	Type 4X/IP66 ^⑤	Type 12/IP65	Component	
	Motor Voltage ^②	Single-Phase		Three-Phase	Catalog Number ^④	Catalog Number ^④	Catalog Number ^④	Catalog Number ^④
Size M								
80	115	7-1/2	—	120	ECX11M1AAA- ₋	ECX11M4AAA- ₋	ECX11M8AAA- ₋	XTAE080F00A- ₋
	208	15	25	120	ECX11M1AAA- ₋	ECX11M4AAA- ₋	ECX11M8AAA- ₋	XTAE080F00A- ₋
	230	15	30	120	ECX11M1AAA- ₋	ECX11M4AAA- ₋	ECX11M8AAA- ₋	XTAE080F00A- ₋
	380	—	50	110	ECX11M1AAA- ₋	ECX11M4AAA- ₋	ECX11M8AAA- ₋	XTAE080F00A- ₋
	460	—	60	120	ECX11M1AAA- ₋	ECX11M4AAA- ₋	ECX11M8AAA- ₋	XTAE080F00A- ₋
	575	—	75	120	ECX11M1AAA- ₋	ECX11M4AAA- ₋	ECX11M8AAA- ₋	XTAE080F00A- ₋
Size N								
95	115	7-1/2	—	120	ECX11N1AAA- ₋	ECX11N4AAA- ₋	ECX11N8AAA- ₋	XTAE095F00A- ₋
	208	15	25	120	ECX11N1AAA- ₋	ECX11N4AAA- ₋	ECX11N8AAA- ₋	XTAE095F00A- ₋
	230	15	40	120	ECX11N1AAA- ₋	ECX11N4AAA- ₋	ECX11N8AAA- ₋	XTAE095F00A- ₋
	380	—	60	110	ECX11N1AAA- ₋	ECX11N4AAA- ₋	ECX11N8AAA- ₋	XTAE095F00A- ₋
	460	—	75	120	ECX11N1AAA- ₋	ECX11N4AAA- ₋	ECX11N8AAA- ₋	XTAE095F00A- ₋
	575	—	100	120	ECX11N1AAA- ₋	ECX11N4AAA- ₋	ECX11N8AAA- ₋	XTAE095F00A- ₋
Size P								
115	115	10	—	120	ECX11P1AAA- ₋	ECX11P4AAA- ₋	ECX11P8AAA- ₋	XTAE115G00A- ₋
	208	25	40	120	ECX11P1AAA- ₋	ECX11P4AAA- ₋	ECX11P8AAA- ₋	XTAE115G00A- ₋
	230	25	50	120	ECX11P1AAA- ₋	ECX11P4AAA- ₋	ECX11P8AAA- ₋	XTAE115G00A- ₋
	380	—	60	110	ECX11P1AAA- ₋	ECX11P4AAA- ₋	ECX11P8AAA- ₋	XTAE115G00A- ₋
	460	—	100	120	ECX11P1AAA- ₋	ECX11P4AAA- ₋	ECX11P8AAA- ₋	XTAE115G00A- ₋
	575	—	125	120	ECX11P1AAA- ₋	ECX11P4AAA- ₋	ECX11P8AAA- ₋	XTAE115G00A- ₋
Size Q								
150	115	15	—	120	ECX11Q1AAA- ₋	ECX11Q4AAA- ₋	ECX11Q8AAA- ₋	XTAE150G00A- ₋
	208	25	40	120	ECX11Q1AAA- ₋	ECX11Q4AAA- ₋	ECX11Q8AAA- ₋	XTAE150G00A- ₋
	230	30	60	120	ECX11Q1AAA- ₋	ECX11Q4AAA- ₋	ECX11Q8AAA- ₋	XTAE150G00A- ₋
	380	—	60	110	ECX11Q1AAA- ₋	ECX11Q4AAA- ₋	ECX11Q8AAA- ₋	XTAE150G00A- ₋
	460	—	125	120	ECX11Q1AAA- ₋	ECX11Q4AAA- ₋	ECX11Q8AAA- ₋	XTAE150G00A- ₋
	575	—	150	120	ECX11Q1AAA- ₋	ECX11Q4AAA- ₋	ECX11Q8AAA- ₋	XTAE150G00A- ₋

Notes

- ① 1 hp = 0.746 kW.
- ② Contact factory for other voltage options.
- ③ Voltage is listed at 60 Hz unless otherwise noted. Other voltages available upon request.
- ④ Select proper "XTOB" overload amperage range as per motor FLA, see **Page V10-T3-9**.
- ⑤ The catalog numbers listed in the Type 4X column are for Type 4X 304-Grade stainless steel, as indicated by the **seventh** digit.
Example: ECX11M4AAA-₋. To order Type 4X 316-Grade stainless steel, change that digit to **9**. To order Type 4 painted steel, change that digit to **3**. To order non-metallic, change that digit to **5**. For details on these alternate enclosures, see **Tab 13**.

Combination Starters**Class ECX19—Combination Non-Reversing Starter—Fusible/Non-Fusible Disconnect**

Amps	Maximum hp ^①		Coil Voltage at 60 Hz ^③	Fuse Clips	Type 1/IP23 Catalog Number ^④	Type 4X/IP66 ^⑤ Catalog Number ^④	Type 12/IP65 Catalog Number ^④	Component Catalog Number ^④
	Motor Voltage ^②	Single-Phase						
Size B								
7	—	—	—	30 A	ECX19B1AAA_-	ECX19B4AAA_-	ECX19B8AAA_-	XTAE007B10A_
	115	1/4	—	120	ECX19B1AAC_-	ECX19B4AAC_-	ECX19B8AAC_-	XTAE007B10A_
	208	3/4	1-1/2	208	ECX19B1EAC_-	ECX19B4EAC_-	ECX19B8EAC_-	XTAE007B10E_
	230	1	2	240	ECX19B1BAC_-	ECX19B4BAC_-	ECX19B8BAC_-	XTAE007B10B_
	380	—	3	380/50 Hz	ECX19B1LAC_-	ECX19B4LAC_-	ECX19B8LAC_-	XTAE007B10L_
	460	—	3	480	ECX19B1CAC_-	ECX19B4CAC_-	ECX19B8CAC_-	XTAE007B10C_
	575	—	5	600	ECX19B1DAC_-	ECX19B4DAC_-	ECX19B8DAC_-	XTAE007B10D_
Size C								
9	—	—	—	30 A	ECX19C1AAA_-	ECX19C4AAA_-	ECX19C8AAA_-	XTAE009B10A_
	115	1/2	—	120	ECX19C1AAC_-	ECX19C4AAC_-	ECX19C8AAC_-	XTAE009B10A_
	208	1	2	208	ECX19C1EAC_-	ECX19C4EAC_-	ECX19C8EAC_-	XTAE009B10E_
	230	1-1/2	3	240	ECX19C1BAC_-	ECX19C4BAC_-	ECX19C8BAC_-	XTAE009B10B_
	380	—	5	380/50 Hz	ECX19C1LAC_-	ECX19C4LAC_-	ECX19C8LAC_-	XTAE009B10L_
	460	—	5	480	ECX19C1CAC_-	ECX19C4CAC_-	ECX19C8CAC_-	XTAE009B10C_
	575	—	7-1/2	600	ECX19C1DAC_-	ECX19C4DAC_-	ECX19C8DAC_-	XTAE009B10D_
Size D								
12	—	—	—	30 A	ECX19D1AAA_-	ECX19D4AAA_-	ECX19D8AAA_-	XTAE012B10A_
	115	1/2	—	120	ECX19D1AAC_-	ECX19D4AAC_-	ECX19D8AAC_-	XTAE012B10A_
	208	1-1/2	3	208	ECX19D1EAC_-	ECX19D4EAC_-	ECX19D8EAC_-	XTAE012B10E_
	230	2	3	240	ECX19D1BAC_-	ECX19D4BAC_-	ECX19D8BAC_-	XTAE012B10B_
	380	—	5	380/50 Hz	ECX19D1LAC_-	ECX19D4LAC_-	ECX19D8LAC_-	XTAE012B10L_
	460	—	7-1/2	480	ECX19D1CAC_-	ECX19D4CAC_-	ECX19D8CAC_-	XTAE012B10C_
	575	—	10	600	ECX19D1DAC_-	ECX19D4DAC_-	ECX19D8DAC_-	XTAE012B10D_
Size E								
15	—	—	—	30 A	ECX19E1AAA_-	ECX19E4AAA_-	ECX19E8AAA_-	XTAE015B10A_
	115	3/4	—	120	ECX19E1AAC_-	ECX19E4AAC_-	ECX19E8AAC_-	XTAE015B10A_
	208	2	3	208	ECX19E1EAC_-	ECX19E4EAC_-	ECX19E8EAC_-	XTAE015B10E_
	230	2	3	240	ECX19E1BAC_-	ECX19E4BAC_-	ECX19E8BAC_-	XTAE015B10B_
	380	—	5	380/50 Hz	ECX19E1LAC_-	ECX19E4LAC_-	ECX19E8LAC_-	XTAE015B10L_
	460	—	7-1/2	480	ECX19E1CAC_-	ECX19E4CAC_-	ECX19E8CAC_-	XTAE015B10C_
	575	—	10	600	ECX19E1DAC_-	ECX19E4DAC_-	ECX19E8DAC_-	XTAE015B10D_

Notes

① 1 hp = 0.746 kW.

② Contact factory for other voltage options.

③ Voltage is listed at 60 Hz unless otherwise noted. Other voltages available upon request.

④ Select proper "XTOB" overload amperage range as per motor FLA, see **Page V10-T3-9**.

⑤ The catalog numbers listed in the Type 4X column are for Type 4X 304-Grade stainless steel, as indicated by the **seventh** digit.

Example: ECX19B4AAA_- . To order Type 4X 316-Grade stainless steel, change that digit to **9**. To order Type 4 painted steel, change that digit to **3**. To order non-metallic, change that digit to **5**. For details on these alternate enclosures, see **Tab 13**.

3.1

IEC Contactors and Starters

XT IEC Power Control

3

Class ECX19—Combination Non-Reversing Starter—Fusible/Non-Fusible Disconnect, continued

Amps	Maximum hp ^①		Coil Voltage at 60 Hz ^③	Fuse Clips	Type 1/IP23 Catalog Number ^④	Type 4X/IP66 ^⑤ Catalog Number ^④	Type 12/IP65 Catalog Number ^④	Component	
	Motor Voltage ^②	Single-Phase						Three-Phase	Catalog Number ^④
Size F									
18	—	—	—	30 A	ECX19F1AAA_	ECX19F4AAA_	ECX19F8AAA_	XTAE018C10A_	
	115	2	—	120	ECX19F1AAC_	ECX19F4AAC_	ECX19F8AAC_	XTAE018C10A_	
	208	2	5	208	ECX19F1EAC_	ECX19F4EAC_	ECX19F8EAC_	XTAE018C10E_	
	230	3	5	240	ECX19F1BAC_	ECX19F4BAC_	ECX19F8BAC_	XTAE018C10B_	
	380	—	7-1/2	380/50 Hz	ECX19F1LAC_	ECX19F4LAC_	ECX19F8LAC_	XTAE018C10L_	
	460	—	10	480	ECX19F1CAC_	ECX19F4CAC_	ECX19F8CAC_	XTAE018C10C_	
	575	—	15	600	ECX19F1DAC_	ECX19F4DAC_	ECX19F8DAC_	XTAE018C10D_	
Size G									
25	—	—	—	30 A	ECX19G1AAA_	ECX19G4AAA_	ECX19G8AAA_	XTAE025C10A_	
	115	2	—	120	ECX19G1AAC_	ECX19G4AAC_	ECX19G8AAC_	XTAE025C10A_	
	208	3	7-1/2	208	ECX19G1EAC_	ECX19G4EAC_	ECX19G8EAC_	XTAE025C10E_	
	230	5	7-1/2	240	ECX19G1BAC_	ECX19G4BAC_	ECX19G8BAC_	XTAE025C10B_	
	380	—	10	380/50 Hz	ECX19G1LAC_	ECX19G4LAC_	ECX19G8LAC_	XTAE025C10L_	
	460	—	15	480	ECX19G1CAC_	ECX19G4CAC_	ECX19G8CAC_	XTAE025C10C_	
	575	—	20	600	ECX19G1DAC_	ECX19G4DAC_	ECX19G8DAC_	XTAE025C10D_	
Size H									
32	—	—	—	60 A	ECX19H1AAA_	ECX19H4AAA_	ECX19H8AAA_	XTAE032C10A_	
	115	3	—	120	ECX19H1AAE_	ECX19H4AAE_	ECX19H8AAE_	XTAE032C10A_	
	208	5	10	208	ECX19H1EAE_	ECX19H4EAE_	ECX19H8EAE_	XTAE032C10E_	
	230	5	10	240	ECX19H1BAE_	ECX19H4BAE_	ECX19H8BAE_	XTAE032C10B_	
	380	—	15	380/50 Hz	ECX19H1LAE_	ECX19H4LAE_	ECX19H8LAE_	XTAE032C10L_	
	460	—	20	480	ECX19H1CAE_	ECX19H4CAE_	ECX19H8CAE_	XTAE032C10C_	
	575	—	25	600	ECX19H1DAE_	ECX19H4DAE_	ECX19H8DAE_	XTAE032C10D_	
Size J									
40	—	—	—	60 A	ECX19J1AAA_	ECX19J4AAA_	ECX19J8AAA_	XTAE040D00A_	
	115	3	—	120	ECX19J1AAE_	ECX19J4AAE_	ECX19J8AAE_	XTAE040D00A_	
	208	5	10	208	ECX19J1EAE_	ECX19J4EAE_	ECX19J8EAE_	XTAE040D00E_	
	230	7-1/2	15	240	ECX19J1BAE_	ECX19J4BAE_	ECX19J8BAE_	XTAE040D00B_	
	380	—	15	380/50 Hz	ECX19J1LAE_	ECX19J4LAE_	ECX19J8LAE_	XTAE040D00L_	
	460	—	30	480	ECX19J1CAE_	ECX19J4CAE_	ECX19J8CAE_	XTAE040D00C_	
	575	—	40	600	ECX19J1DAE_	ECX19J4DAE_	ECX19J8DAE_	XTAE040D00D_	
Size K									
50	—	—	—	100 A	ECX19K1AAA_	ECX19K4AAA_	ECX19K8AAA_	XTAE050D00A_	
	115	3	—	120	ECX19K1AAE_	ECX19K4AAE_	ECX19K8AAE_	XTAE050D00A_	
	208	7-1/2	15	208	ECX19K1EAE_	ECX19K4EAE_	ECX19K8EAE_	XTAE050D00E_	
	230	10	20	240	ECX19K1BAE_	ECX19K4BAE_	ECX19K8BAE_	XTAE050D00B_	
	380	—	20	380/50 Hz	ECX19K1LAE_	ECX19K4LAE_	ECX19K8LAE_	XTAE050D00L_	
	460	—	40	480	ECX19K1CAE_	ECX19K4CAE_	ECX19K8CAE_	XTAE050D00C_	
	575	—	50	600	ECX19K1DAE_	ECX19K4DAE_	ECX19K8DAE_	XTAE050D00D_	

Notes

- ① 1 hp = 0.746 kW.
- ② Contact factory for other voltage options.
- ③ Voltage is listed at 60 Hz unless otherwise noted. Other voltages available upon request.
- ④ Select proper "XTOB" overload amperage range as per motor FLA, see **Page V10-T3-9**.
- ⑤ The catalog numbers listed in the Type 4X column are for Type 4X 304-Grade stainless steel, as indicated by the **seventh** digit.
Example: ECX19F4AAA_-. To order Type 4X 316-Grade stainless steel, change that digit to **9**. To order Type 4 painted steel, change that digit to **3**. To order non-metallic, change that digit to **5**. For details on these alternate enclosures, see **Tab 13**.

Class ECX19—Combination Non-Reversing Starter—Fusible/Non-Fusible Disconnect, continued

Amps	Maximum hp ^①		Coil Voltage at 60 Hz ^②	Fuse Clips	Type 1/IP23 Catalog Number ^④	Type 4X/IP66 ^⑤ Catalog Number ^④	Type 12/IP65 Catalog Number ^④	Component Catalog Number ^④
	Motor Voltage ^②	Single-Phase						
Size L								
65	—	—	—	100 A	ECX19L1AAA_-	ECX19L4AAA_-	ECX19L8AAA_-	XTAE065D00A_-
	115	5	—	120	ECX19L1AAG_-	ECX19L4AAG_-	ECX19L8AAG_-	XTAE065D00A_-
	208	10	20	208	ECX19L1EAG_-	ECX19L4EAG_-	ECX19L8EAG_-	XTAE065D00E_-
	230	15	25	240	ECX19L1BAG_-	ECX19L4BAG_-	ECX19L8BAG_-	XTAE065D00B_-
	380	—	30	380/50 Hz	ECX19L1LAG_-	ECX19L4LAG_-	ECX19L8LAG_-	XTAE065D00L_-
	460	—	50	480	ECX19L1CAG_-	ECX19L4CAG_-	ECX19L8CAG_-	XTAE065D00C_-
	575	—	60	600	ECX19L1DAG_-	ECX19L4DAG_-	ECX19L8DAG_-	XTAE065D00D_-
Size M								
80	—	—	—	100 A	ECX19M1AAA_-	ECX19M4AAA_-	ECX19M8AAA_-	XTAE080F00A_-
	115	7-1/2	—	120	ECX19M1AAG_-	ECX19M4AAG_-	ECX19M8AAG_-	XTAE080F00A_-
	208	15	25	208	ECX19M1EAG_-	ECX19M4EAG_-	ECX19M8EAG_-	XTAE080F00E_-
	230	15	30	240	ECX19M1BAG_-	ECX19M4BAG_-	ECX19M8BAG_-	XTAE080F00B_-
	380	—	50	380/50 Hz	ECX19M1LAG_-	ECX19M4LAG_-	ECX19M8LAG_-	XTAE080F00L_-
	460	—	60	480	ECX19M1CAG_-	ECX19M4CAG_-	ECX19M8CAG_-	XTAE080F00C_-
	575	—	75	600	ECX19M1DAG_-	ECX19M4DAG_-	ECX19M8DAG_-	XTAE080F00D_-
Size N ^⑥								
95	—	—	—	⑥	ECX19N1AAA_-	ECX19N4AAA_-	ECX19N8AAA_-	XTAE095F00A_-
	115	7-1/2	—	120	ECX19N1AAG_-	ECX19N4AAG_-	ECX19N8AAG_-	XTAE095F00A_-
	208	15	25	208	ECX19N1EAG_-	ECX19N4EAG_-	ECX19N8EAG_-	XTAE095F00E_-
	230	15	40	240	ECX19N1BAG_-	ECX19N4BAG_-	ECX19N8BAG_-	XTAE095F00B_-
	380	—	60	380/50 Hz	ECX19N1LAG_-	ECX19N4LAG_-	ECX19N8LAG_-	XTAE095F00L_-
	460	—	75	480	ECX19N1CAG_-	ECX19N4CAG_-	ECX19N8CAG_-	XTAE095F00C_-
	575	—	100	600	ECX19N1DAG_-	ECX19N4DAG_-	ECX19N8DAG_-	XTAE095F00D_-
Size P ^⑥								
105	—	—	—	⑥	ECX19P1AAA_-	ECX19P4AAA_-	ECX19P8AAA_-	XTAE115G00A_-
	115	10	—	120	ECX19P1AAG_-	ECX19P4AAG_-	ECX19P8AAG_-	XTAE115G00A_-
	208	25	30	208	ECX19P1EAG_-	ECX19P4EAG_-	ECX19P8EAG_-	XTAE115G00E_-
	230	25	40	240	ECX19P1BAG_-	ECX19P4BAG_-	ECX19P8BAG_-	XTAE115G00B_-
	380	—	60	380/50 Hz	ECX19P1LAG_-	ECX19P4LAG_-	ECX19P8LAG_-	XTAE115G00L_-
	460	—	75	480	ECX19P1CAG_-	ECX19P4CAG_-	ECX19P8CAG_-	XTAE115G00C_-
	575	—	100	600	ECX19P1DAG_-	ECX19P4DAG_-	ECX19P8DAG_-	XTAE115G00D_-

Notes

- ① 1 hp = 0.746 kW.
 ② Contact factory for other voltage options.
 ③ Voltage is listed at 60 Hz unless otherwise noted. Other voltages available upon request.
 ④ Select proper "XTOB" overload amperage range as per motor FLA, see **Page V10-T3-9**.
 ⑤ The catalog numbers listed in the Type 4X column are for Type 4X 304-Grade stainless steel, as indicated by the **seventh** digit.
 Example: ECX19L4AAA_- . To order Type 4X 316-Grade stainless steel, change that digit to **9**. To order Type 4 painted steel, change that digit to **3**.
 To order non-metallic, change that digit to **5**. For details on these alternate enclosures, see **Tab 13**.
 ⑥ Non-fused disconnect only.

3.1

IEC Contactors and Starters

XT IEC Power Control

3

Class ECX20—Combination Reversing Starter—Fusible/Non-Fusible Disconnect

Amps	Maximum hp ^①		Coil Voltage at 60 Hz ^③	Fuse Clips	Type 1/IP23 Catalog Number ^④	Type 4X/IP66 ^⑤ Catalog Number ^④	Type 12/IP65 Catalog Number ^④	Component	
	Motor Voltage ^②	Single-Phase						Three-Phase	Catalog Number ^④
Size B									
7	—	—	—	30 A	ECX20B1AAA_	ECX20B4AAA_	ECX20B8AAA_	XTAR007B10A_	
	115	1/4	—	120	ECX20B1AAC_	ECX20B4AAC_	ECX20B8AAC_	XTAR007B10A_	
	208	3/4	1-1/2	208	ECX20B1EAC_	ECX20B4EAC_	ECX20B8EAC_	XTAR007B10E_	
	230	1	2	240	ECX20B1BAC_	ECX20B4BAC_	ECX20B8BAC_	XTAR007B10B_	
	380	—	3	380/50 Hz	ECX20B1LAC_	ECX20B4LAC_	ECX20B8LAC_	XTAR007B10L_	
	460	—	3	480	ECX20B1CAC_	ECX20B4CAC_	ECX20B8CAC_	XTAR007B10C_	
	575	—	5	600	ECX20B1DAC_	ECX20B4DAC_	ECX20B8DAC_	XTAR007B10D_	
Size C									
9	—	—	—	30 A	ECX20C1AAA_	ECX20C4AAA_	ECX20C8AAA_	XTAR009B10A_	
	115	1/2	—	120	ECX20C1AAC_	ECX20C4AAC_	ECX20C8AAC_	XTAR009B10A_	
	208	1	2	208	ECX20C1EAC_	ECX20C4EAC_	ECX20C8EAC_	XTAR009B10E_	
	230	1-1/2	3	240	ECX20C1BAC_	ECX20C4BAC_	ECX20C8BAC_	XTAR009B10B_	
	380	—	5	380/50 Hz	ECX20C1LAC_	ECX20C4LAC_	ECX20C8LAC_	XTAR009B10L_	
	460	—	5	480	ECX20C1CAC_	ECX20C4CAC_	ECX20C8CAC_	XTAR009B10C_	
	575	—	7-1/2	600	ECX20C1DAC_	ECX20C4DAC_	ECX20C8DAC_	XTAR009B10D_	
Size D									
12	—	—	—	30 A	ECX20D1AAA_	ECX20D4AAA_	ECX20D8AAA_	XTAR012B10A_	
	115	1/2	—	120	ECX20D1AAC_	ECX20D4AAC_	ECX20D8AAC_	XTAR012B10A_	
	208	1-1/2	3	208	ECX20D1EAC_	ECX20D4EAC_	ECX20D8EAC_	XTAR012B10E_	
	230	2	3	240	ECX20D1BAC_	ECX20D4BAC_	ECX20D8BAC_	XTAR012B10B_	
	380	—	5	380/50 Hz	ECX20D1LAC_	ECX20D4LAC_	ECX20D8LAC_	XTAR012B10L_	
	460	—	7-1/2	480	ECX20D1CAC_	ECX20D4CAC_	ECX20D8CAC_	XTAR012B10C_	
	575	—	10	600	ECX20D1DAC_	ECX20D4DAC_	ECX20D8DAC_	XTAR012B10D_	
Size E									
15	—	—	—	30 A	ECX20E1AAA_	ECX20E4AAA_	ECX20E8AAA_	XTAR015B10A_	
	115	3/4	—	120	ECX20E1AAC_	ECX20E4AAC_	ECX20E8AAC_	XTAR015B10A_	
	208	2	3	208	ECX20E1EAC_	ECX20E4EAC_	ECX20E8EAC_	XTAR015B10E_	
	230	2	3	240	ECX20E1BAC_	ECX20E4BAC_	ECX20E8BAC_	XTAR015B10B_	
	380	—	5	380/50 Hz	ECX20E1LAC_	ECX20E4LAC_	ECX20E8LAC_	XTAR015B10L_	
	460	—	7-1/2	480	ECX20E1CAC_	ECX20E4CAC_	ECX20E8CAC_	XTAR015B10C_	
	575	—	10	600	ECX20E1DAC_	ECX20E4DAC_	ECX20E8DAC_	XTAR015B10D_	

Notes

- ① 1 hp = 0.746 kW.
- ② Contact factory for other voltage options.
- ③ Voltage is listed at 60 Hz unless otherwise noted. Other voltages available upon request.
- ④ Select proper "XTOB" overload amperage range as per motor FLA, see **Page V10-T3-9**.
- ⑤ The catalog numbers listed in the Type 4X column are for Type 4X 304-Grade stainless steel, as indicated by the **seventh** digit.
Example: ECX20B4AAA_ To order Type 4X 316-Grade stainless steel, change that digit to **9**. To order Type 4 painted steel, change that digit to **3**. To order non-metallic, change that digit to **5**. For details on these alternate enclosures, see **Tab 13**.

Class ECX20—Combination Reversing Starter—Fusible/Non-Fusible Disconnect, continued

Amps	Maximum hp ^①		Coil Voltage at 60 Hz ^③	Fuse Clips	Type 1/IP23 Catalog Number ^④	Type 4X/IP66 ^⑤ Catalog Number ^④	Type 12/IP65 Catalog Number ^④	Component	
	Motor Voltage ^②	Single-Phase						Three-Phase	Catalog Number ^④
Size F									
18	—	—	—	30 A	ECX20F1AAA_-	ECX20F4AAA_-	ECX20F8AAA_-	XTAR018C10A_	
	115	2	—	120	ECX20F1AAC_-	ECX20F4AAC_-	ECX20F8AAC_-	XTAR018C10A_	
	208	2	5	208	ECX20F1EAC_-	ECX20F4EAC_-	ECX20F8EAC_-	XTAR018C10E_	
	230	3	5	240	ECX20F1BAC_-	ECX20F4BAC_-	ECX20F8BAC_-	XTAR018C10B_	
	380	—	7-1/2	380/50 Hz	ECX20F1LAC_-	ECX20F4LAC_-	ECX20F8LAC_-	XTAR018C10L_	
	460	—	10	480	ECX20F1CAC_-	ECX20F4CAC_-	ECX20F8CAC_-	XTAR018C10C_	
	575	—	15	600	ECX20F1DAC_-	ECX20F4DAC_-	ECX20F8DAC_-	XTAR018C10D_	
Size G									
25	—	—	—	30 A	ECX20G1AAA_-	ECX20G4AAA_-	ECX20G8AAA_-	XTAR025C10A_	
	115	2	—	120	ECX20G1AAC_-	ECX20G4AAC_-	ECX20G8AAC_-	XTAR025C10A_	
	208	3	7-1/2	208	ECX20G1EAC_-	ECX20G4EAC_-	ECX20G8EAC_-	XTAR025C10E_	
	230	5	7-1/2	240	ECX20G1BAC_-	ECX20G4BAC_-	ECX20G8BAC_-	XTAR025C10B_	
	380	—	10	380/50 Hz	ECX20G1LAC_-	ECX20G4LAC_-	ECX20G8LAC_-	XTAR025C10L_	
	460	—	15	480	ECX20G1CAC_-	ECX20G4CAC_-	ECX20G8CAC_-	XTAR025C10C_	
	575	—	20	600	ECX20G1DAC_-	ECX20G4DAC_-	ECX20G8DAC_-	XTAR025C10D_	
Size H									
32	—	—	—	60 A	ECX20H1AAA_-	ECX20H4AAA_-	ECX20H8AAA_-	XTAR032C10A_	
	115	3	—	120	ECX20H1AAE_-	ECX20H4AAE_-	ECX20H8AAE_-	XTAR032C10A_	
	208	5	10	208	ECX20H1EAE_-	ECX20H4EAE_-	ECX20H8EAE_-	XTAR032C10E_	
	230	5	10	240	ECX20H1BAE_-	ECX20H4BAE_-	ECX20H8BAE_-	XTAR032C10B_	
	380	—	15	380/50 Hz	ECX20H1LAE_-	ECX20H4LAE_-	ECX20H8LAE_-	XTAR032C10L_	
	460	—	20	480	ECX20H1CAE_-	ECX20H4CAE_-	ECX20H8CAE_-	XTAR032C10C_	
	575	—	25	600	ECX20H1DAE_-	ECX20H4DAE_-	ECX20H8DAE_-	XTAR032C10D_	
Size J									
40	—	—	—	60 A	ECX20J1AAA_-	ECX20J4AAA_-	ECX20J8AAA_-	XTAR040D00A_	
	115	3	—	120	ECX20J1AAE_-	ECX20J4AAE_-	ECX20J8AAE_-	XTAR040D00A_	
	208	5	10	208	ECX20J1EAE_-	ECX20J4EAE_-	ECX20J8EAE_-	XTAR040D00E_	
	230	7-1/2	15	240	ECX20J1BAE_-	ECX20J4BAE_-	ECX20J8BAE_-	XTAR040D00B_	
	380	—	15	380/50 Hz	ECX20J1LAE_-	ECX20J4LAE_-	ECX20J8LAE_-	XTAR040D00L_	
	460	—	30	480	ECX20J1CAE_-	ECX20J4CAE_-	ECX20J8CAE_-	XTAR040D00C_	
	575	—	40	600	ECX20J1DAE_-	ECX20J4DAE_-	ECX20J8DAE_-	XTAR040D00D_	
Size K									
50	—	—	—	100 A	ECX20K1AAA_-	ECX20K4AAA_-	ECX20K8AAA_-	XTAR050D00A_	
	115	3	—	120	ECX20K1AAG_-	ECX20K4AAG_-	ECX20K8AAG_-	XTAR050D00A_	
	208	7-1/2	15	208	ECX20K1EAG_-	ECX20K4EAG_-	ECX20K8EAG_-	XTAR050D00E_	
	230	10	20	240	ECX20K1BAG_-	ECX20K4BAG_-	ECX20K8BAG_-	XTAR050D00B_	
	380	—	20	380/50 Hz	ECX20K1LAG_-	ECX20K4LAG_-	ECX20K8LAG_-	XTAR050D00L_	
	460	—	40	480	ECX20K1CAG_-	ECX20K4CAG_-	ECX20K8CAG_-	XTAR050D00C_	
	575	—	50	600	ECX20K1DAG_-	ECX20K4DAG_-	ECX20K8DAG_-	XTAR050D00D_	

Notes

① 1 hp = 0.746 kW.

② Contact factory for other voltage options.

③ Voltage is listed at 60 Hz unless otherwise noted. Other voltages available upon request.

④ Select proper "XTOB" overload amperage range as per motor FLA, see **Page V10-T3-9**.

⑤ The catalog numbers listed in the Type 4X column are for Type 4X 304-Grade stainless steel, as indicated by the **seventh** digit.

Example: ECX20F4AAA_-. To order Type 4X 316-Grade stainless steel, change that digit to **9**. To order Type 4 painted steel, change that digit to **3**.

To order non-metallic, change that digit to **5**. For details on these alternate enclosures, see **Tab 13**.

3.1

IEC Contactors and Starters

XT IEC Power Control

3

Class ECX20—Combination Reversing Starter—Fusible/Non-Fusible Disconnect, continued

Amps	Maximum hp ^①		Coil Voltage at 60 Hz ^③	Fuse Clips	Type 1/IP23 Catalog Number ^④	Type 4X/IP66 ^⑤ Catalog Number ^④	Type 12/IP65 Catalog Number ^④	Component	
	Motor Voltage ^②	Single-Phase						Three-Phase	Catalog Number ^④
Size L									
65	—	—	—	100 A	ECX20L1AAA_	ECX20L4AAA_	ECX20L8AAA_	XTAR065D00A_	
	115	5	—	120	ECX20L1AAG_	ECX20L4AAG_	ECX20L8AAG_	XTAR065D00A_	
	208	10	20	208	ECX20L1EAG_	ECX20L4EAG_	ECX20L8EAG_	XTAR065D00E_	
	230	15	25	240	ECX20L1BAG_	ECX20L4BAG_	ECX20L8BAG_	XTAR065D00B_	
	380	—	30	380/50 Hz	ECX20L1LAG_	ECX20L4LAG_	ECX20L8LAG_	XTAR065D00L_	
	460	—	50	480	ECX20L1CAG_	ECX20L4CAG_	ECX20L8CAG_	XTAR065D00C_	
	575	—	60	600	ECX20L1DAG_	ECX20L4DAG_	ECX20L8DAG_	XTAR065D00D_	
Size M									
80	—	—	—	100 A	ECX20M1AAA_	ECX20M4AAA_	ECX20M8AAA_	XTAR080F00A_	
	115	7-1/2	—	120	ECX20M1AAG_	ECX20M4AAG_	ECX20M8AAG_	XTAR080F00A_	
	208	15	25	208	ECX20M1EAG_	ECX20M4EAG_	ECX20M8EAG_	XTAR080F00E_	
	230	15	30	240	ECX20M1BAG_	ECX20M4BAG_	ECX20M8BAG_	XTAR080F00B_	
	380	—	50	380/50 Hz	ECX20M1LAG_	ECX20M4LAG_	ECX20M8LAG_	XTAR080F00L_	
	460	—	60	480	ECX20M1CAG_	ECX20M4CAG_	ECX20M8CAG_	XTAR080F00C_	
	575	—	75	600	ECX20M1DAG_	ECX20M4DAG_	ECX20M8DAG_	XTAR080F00D_	
Size N ^⑥									
95	—	—	—	⑥	ECX20N1AAA_	ECX20N4AAA_	ECX20N8AAA_	XTAR095F00A_	
	115	7-1/2	—	120	ECX20N1AAA_	ECX20N4AAA_	ECX20N8AAA_	XTAR095F00A_	
	208	15	25	208	ECX20N1EAA_	ECX20N4EAA_	ECX20N8EAA_	XTAR095F00E_	
	230	15	40	240	ECX20N1BAA_	ECX20N4BAA_	ECX20N8BAA_	XTAR095F00B_	
	380	—	60	380/50 Hz	ECX20N1LAA_	ECX20N4LAA_	ECX20N8LAA_	XTAR095F00L_	
	460	—	75	480	ECX20N1CAA_	ECX20N4CAA_	ECX20N8CAA_	XTAR095F00C_	
	575	—	100	600	ECX20N1DAA_	ECX20N4DAA_	ECX20N8DAA_	XTAR095F00D_	
Size P ^⑥									
105	—	—	—	⑥	ECX20P1AAA_	ECX20P4AAA_	ECX20P8AAA_	XTAR115G00A_	
	115	10	—	120	ECX20P1AAA_	ECX20P4AAA_	ECX20P8AAA_	XTAR115G00A_	
	208	25	30	208	ECX20P1EAA_	ECX20P4EAA_	ECX20P8EAA_	XTAR115G00E_	
	230	25	40	240	ECX20P1BAA_	ECX20P4BAA_	ECX20P8BAA_	XTAR115G00B_	
	380	—	60	380/50 Hz	ECX20P1LAA_	ECX20P4LAA_	ECX20P8LAA_	XTAR115G00L_	
	460	—	75	480	ECX20P1CAA_	ECX20P4CAA_	ECX20P8CAA_	XTAR115G00C_	
	575	—	100	600	ECX20P1DAA_	ECX20P4DAA_	ECX20P8DAA_	XTAR115G00D_	

Notes

- ① 1 hp = 0.746 kW.
- ② Contact factory for other voltage options.
- ③ Voltage is listed at 60 Hz unless otherwise noted. Other voltages available upon request.
- ④ Select proper "XTOB" overload amperage range as per motor FLA, see **Page V10-T3-9**.
- ⑤ The catalog numbers listed in the Type 4X column are for Type 4X 304-Grade stainless steel, as indicated by the **seventh** digit. Example: ECX20L4AAA_-. To order Type 4X 316-Grade stainless steel, change that digit to **9**. To order Type 4 painted steel, change that digit to **3**. To order non-metallic, change that digit to **5**. For details on these alternate enclosures, see **Tab 13**.
- ⑥ Non-fused disconnect only.

Class ECX25—Combination Non-Reversing Starter—Circuit Breaker

Amps	Maximum hp ^①		Coil Voltage at 60 Hz ^③	Circuit Breaker	Type 1/IP23 Catalog Number ^④	Type 4X/IP66 ^⑤ Catalog Number ^④	Type 12/IP65 Catalog Number ^④	Component Catalog Number ^④	
	Motor Voltage ^②	Single-Phase							Three-Phase
Size B									
7	115	1/4	—	120	7 A	ECX25B1AAC_-	ECX25B4AAC_-	ECX25B8AAC_-	XTAE007B10A_
	208	3/4	1-1/2	208		ECX25B1EAC_-	ECX25B4EAC_-	ECX25B8EAC_-	XTAE007B10E_
	230	1	2	240		ECX25B1BAC_-	ECX25B4BAC_-	ECX25B8BAC_-	XTAE007B10B_
	380	—	3	380/50 Hz		ECX25B1LAC_-	ECX25B4LAC_-	ECX25B8LAC_-	XTAE007B10L_
	460	—	3	480		ECX25B1CAC_-	ECX25B4CAC_-	ECX25B8CAC_-	XTAE007B10C_
	575	—	5	600		ECX25B1DAC_-	ECX25B4DAC_-	ECX25B8DAC_-	XTAE007B10D_
Size C									
9	115	1/2	—	120	15 A	ECX25C1AAD_-	ECX25C4AAD_-	ECX25C8AAD_-	XTAE009B10A_
	208	1	2	208		ECX25C1EAD_-	ECX25C4EAD_-	ECX25C8EAD_-	XTAE009B10E_
	230	1-1/2	3	240		ECX25C1BAD_-	ECX25C4BAD_-	ECX25C8BAD_-	XTAE009B10B_
	380	—	5	380/50 Hz		ECX25C1LAD_-	ECX25C4LAD_-	ECX25C8LAD_-	XTAE009B10L_
	460	—	5	480		ECX25C1CAD_-	ECX25C4CAD_-	ECX25C8CAD_-	XTAE009B10C_
	575	—	7-1/2	600		ECX25C1DAD_-	ECX25C4DAD_-	ECX25C8DAD_-	XTAE009B10D_
Size D									
12	115	1/2	—	120	15 A	ECX25D1AAD_-	ECX25D4AAD_-	ECX25D8AAD_-	XTAE012B10A_
	208	1-1/2	3	208		ECX25D1EAD_-	ECX25D4EAD_-	ECX25D8EAD_-	XTAE012B10E_
	230	2	3	240		ECX25D1BAD_-	ECX25D4BAD_-	ECX25D8BAD_-	XTAE012B10B_
	380	—	5	380/50 Hz		ECX25D1LAD_-	ECX25D4LAD_-	ECX25D8LAD_-	XTAE012B10L_
	460	—	7-1/2	480		ECX25D1CAD_-	ECX25D4CAD_-	ECX25D8CAD_-	XTAE012B10C_
	575	—	10	600		ECX25D1DAD_-	ECX25D4DAD_-	ECX25D8DAD_-	XTAE012B10D_
Size E									
15	115	3/4	—	120	30 A	ECX25E1AAE_-	ECX25E4AAE_-	ECX25E8AAE_-	XTAE015B10A_
	208	2	3	208		ECX25E1EAE_-	ECX25E4EAE_-	ECX25E8EAE_-	XTAE015B10E_
	230	2	3	240		ECX25E1BAE_-	ECX25E4BAE_-	ECX25E8BAE_-	XTAE015B10B_
	380	—	5	380/50 Hz		ECX25E1LAE_-	ECX25E4LAE_-	ECX25E8LAE_-	XTAE015B10L_
	460	—	7-1/2	480		ECX25E1CAE_-	ECX25E4CAE_-	ECX25E8CAE_-	XTAE015B10C_
	575	—	10	600		ECX25E1DAE_-	ECX25E4DAE_-	ECX25E8DAE_-	XTAE015B10D_
Size F									
18	115	2	—	120	30 A	ECX25F1AAE_-	ECX25F4AAE_-	ECX25F8AAE_-	XTAE018C10A_
	208	2	5	208		ECX25F1EAE_-	ECX25F4EAE_-	ECX25F8EAE_-	XTAE018C10E_
	230	3	5	240		ECX25F1BAE_-	ECX25F4BAE_-	ECX25F8BAE_-	XTAE018C10B_
	380	—	7-1/2	380/50 Hz		ECX25F1LAE_-	ECX25F4LAE_-	ECX25F8LAE_-	XTAE018C10L_
	460	—	10	480		ECX25F1CAE_-	ECX25F4CAE_-	ECX25F8CAE_-	XTAE018C10C_
	575	—	15	600		ECX25F1DAE_-	ECX25F4DAE_-	ECX25F8DAE_-	XTAE018C10D_

Notes

- ① 1 hp = 0.746 kW.
 ② Contact factory for other voltage options.
 ③ Voltage is listed at 60 Hz unless otherwise noted. Other voltages available upon request.
 ④ Select proper "XTOB" overload amperage range as per motor FLA, see **Page V10-T3-9**.
 ⑤ The catalog numbers listed in the Type 4X column are for Type 4X 304-Grade stainless steel, as indicated by the **seventh** digit.
 Example: ECX25B4AAA_- . To order Type 4X 316-Grade stainless steel, change that digit to **9**. To order Type 4 painted steel, change that digit to **3**.
 To order non-metallic, change that digit to **5**. For details on these alternate enclosures, see **Tab 13**.

3.1

IEC Contactors and Starters

XT IEC Power Control

3

Class ECX25—Combination Non-Reversing Starter—Circuit Breaker, continued

Amps	Maximum hp ^①		Coil Voltage at 60 Hz ^③	Circuit Breaker	Type 1/IP23 Catalog Number ^④	Type 4X/IP66 ^⑤ Catalog Number ^④	Type 12/IP65 Catalog Number ^④	Component	
	Motor Voltage ^②	Single-Phase						Three-Phase	Catalog Number ^④
Size G									
25	115	2	—	120	50 A	ECX25G1AAF_	ECX25G4AAF_	ECX25G8AAF_	XTAE025C10A_
	208	3	7-1/2	208		ECX25G1EAF_	ECX25G4EAF_	ECX25G8EAF_	XTAE025C10E_
	230	5	7-1/2	240		ECX25G1BAF_	ECX25G4BAF_	ECX25G8BAF_	XTAE025C10B_
	380	—	10	380/50 Hz		ECX25G1LAF_	ECX25G4LAF_	ECX25G8LAF_	XTAE025C10L_
	460	—	15	480		ECX25G1CAF_	ECX25G4CAF_	ECX25G8CAF_	XTAE025C10C_
	575	—	20	600		ECX25G1DAF_	ECX25G4DAF_	ECX25G8DAF_	XTAE025C10D_
	Size H								
32	115	3	—	120	50 A	ECX25H1AAF_	ECX25H4AAF_	ECX25H8AAF_	XTAE032C10A_
	208	5	10	208		ECX25H1EAF_	ECX25H4EAF_	ECX25H8EAF_	XTAE032C10E_
	230	5	10	240		ECX25H1BAF_	ECX25H4BAF_	ECX25H8BAF_	XTAE032C10B_
	380	—	15	380/50 Hz		ECX25H1LAF_	ECX25H4LAF_	ECX25H8LAF_	XTAE032C10L_
	460	—	20	480		ECX25H1CAF_	ECX25H4CAF_	ECX25H8CAF_	XTAE032C10C_
	575	—	25	600		ECX25H1DAF_	ECX25H4DAF_	ECX25H8DAF_	XTAE032C10D_
	Size J								
40	115	3	—	120	50 A	ECX25J1AAF_	ECX25J4AAF_	ECX25J8AAF_	XTAE040D00A_
	208	5	10	208		ECX25J1EAF_	ECX25J4EAF_	ECX25J8EAF_	XTAE040D00E_
	230	7-1/2	15	240		ECX25J1BAF_	ECX25J4BAF_	ECX25J8BAF_	XTAE040D00B_
	380	—	15	380/50 Hz		ECX25J1LAF_	ECX25J4LAF_	ECX25J8LAF_	XTAE040D00L_
	460	—	30	480		ECX25J1CAF_	ECX25J4CAF_	ECX25J8CAF_	XTAE040D00C_
	575	—	40	600		ECX25J1DAF_	ECX25J4DAF_	ECX25J8DAF_	XTAE040D00D_
	Size K								
50	115	3	—	120	70 A	ECX25K1AAW_	ECX25K4AAW_	ECX25K8AAW_	XTAE050D00A_
	208	7-1/2	15	208		ECX25K1EAW_	ECX25K4EAW_	ECX25K8EAW_	XTAE050D00E_
	230	10	20	240		ECX25K1BAW_	ECX25K4BAW_	ECX25K8BAW_	XTAE050D00B_
	380	—	20	380/50 Hz		ECX25K1LAW_	ECX25K4LAW_	ECX25K8LAW_	XTAE050D00L_
	460	—	40	480		ECX25K1CAW_	ECX25K4CAW_	ECX25K8CAW_	XTAE050D00C_
	575	—	50	600		ECX25K1DAW_	ECX25K4DAW_	ECX25K8DAW_	XTAE050D00D_
	Size L								
65	115	5	—	120	70 A	ECX25L1AAW_	ECX25L4AAW_	ECX25L8AAW_	XTAE065D00A_
	208	10	20	208		ECX25L1EAW_	ECX25L4EAW_	ECX25L8EAW_	XTAE065D00E_
	230	15	25	240		ECX25L1BAW_	ECX25L4BAW_	ECX25L8BAW_	XTAE065D00B_
	380	—	30	380/50 Hz		ECX25L1LAW_	ECX25L4LAW_	ECX25L8LAW_	XTAE065D00L_
	460	—	50	480		ECX25L1CAW_	ECX25L4CAW_	ECX25L8CAW_	XTAE065D00C_
	575	—	60	600		ECX25L1DAW_	ECX25L4DAW_	ECX25L8DAW_	XTAE065D00D_

Notes

- ① 1 hp = 0.746 kW.
- ② Contact factory for other voltage options.
- ③ Voltage is listed at 60 Hz unless otherwise noted. Other voltages available upon request.
- ④ Select proper "XTOB" overload amperage range as per motor FLA, see **Page V10-T3-9**.
- ⑤ The catalog numbers listed in the Type 4X column are for Type 4X 304-Grade stainless steel, as indicated by the **seventh** digit.
Example: ECX25G4AAA-_. To order Type 4X 316-Grade stainless steel, change that digit to **9**. To order Type 4 painted steel, change that digit to **3**. To order non-metallic, change that digit to **5**. For details on these alternate enclosures, see **Tab 13**.

Class ECX25—Combination Non-Reversing Starter—Circuit Breaker, continued

Amps	Maximum hp ^①		Coil Voltage at 60 Hz ^③	Circuit Breaker	Type 1/IP23 Catalog Number ^④	Type 4X/IP66 ^⑤ Catalog Number ^④	Type 12/IP65 Catalog Number ^④	Component Catalog Number ^④	
	Motor Voltage ^②	Single-Phase							Three-Phase
Size M									
80	115	7-1/2	—	120	100 A	ECX25M1AAG_-	ECX25M4AAG_-	ECX25M8AAG_-	XTAE080F00A_
	208	15	25	208		ECX25M1EAG_-	ECX25M4EAG_-	ECX25M8EAG_-	XTAE080F00E_
	230	15	30	240		ECX25M1BAG_-	ECX25M4BAG_-	ECX25M8BAG_-	XTAE080F00B_
	380	—	50	380/50 Hz		ECX25M1LAG_-	ECX25M4LAG_-	ECX25M8LAG_-	XTAE080F00L_
	460	—	60	480		ECX25M1CAG_-	ECX25M4CAG_-	ECX25M8CAG_-	XTAE080F00C_
	575	—	75	600		ECX25M1DAG_-	ECX25M4DAG_-	ECX25M8DAG_-	XTAE080F00D_
Size N									
95	115	7-1/2	—	120	100 A	ECX25N1AAG_-	ECX25N4AAG_-	ECX25N8AAG_-	XTAE095F00A_
	208	15	25	208		ECX25N1EAG_-	ECX25N4EAG_-	ECX25N8EAG_-	XTAE095F00E_
	230	15	40	240		ECX25N1BAG_-	ECX25N4BAG_-	ECX25N8BAG_-	XTAE095F00B_
	380	—	60	380/50 Hz		ECX25N1LAG_-	ECX25N4LAG_-	ECX25N8LAG_-	XTAE095F00L_
	460	—	75	480		ECX25N1CAG_-	ECX25N4CAG_-	ECX25N8CAG_-	XTAE095F00C_
	575	—	100	600		ECX25N1DAG_-	ECX25N4DAG_-	ECX25N8DAG_-	XTAE095F00D_
Size P									
115	115	10	—	120	150 A	ECX25P1AAH_-	ECX25P4AAH_-	ECX25P8AAH_-	XTAE115G00A_
	208	25	40	208		ECX25P1EAH_-	ECX25P4EAH_-	ECX25P8EAH_-	XTAE115G00E_
	230	25	50	240		ECX25P1BAH_-	ECX25P4BAH_-	ECX25P8BAH_-	XTAE115G00B_
	380	—	60	380/50 Hz		ECX25P1LAH_-	ECX25P4LAH_-	ECX25P8LAH_-	XTAE115G00L_
	460	—	100	480		ECX25P1CAH_-	ECX25P4CAH_-	ECX25P8CAH_-	XTAE115G00C_
	575	—	125	600		ECX25P1DAH_-	ECX25P4DAH_-	ECX25P8DAH_-	XTAE115G00D_
Size Q									
125	115	15	—	120	150 A	ECX25Q1AAH_-	ECX25Q4AAH_-	ECX25Q8AAH_-	XTAE150G00A_
	208	25	40	208		ECX25Q1EAH_-	ECX25Q4EAH_-	ECX25Q8EAH_-	XTAE150G00E_
	230	25	50	240		ECX25Q1BAH_-	ECX25Q4BAH_-	ECX25Q8BAH_-	XTAE150G00B_
	380	—	75	380/50 Hz		ECX25Q1LAH_-	ECX25Q4LAH_-	ECX25Q8LAH_-	XTAE150G00L_
	460	—	100	480		ECX25Q1CAH_-	ECX25Q4CAH_-	ECX25Q8CAH_-	XTAE150G00C_
	575	—	125	600		ECX25Q1DAH_-	ECX25Q4DAH_-	ECX25Q8DAH_-	XTAE150G00D_

Notes

- ① 1 hp = 0.746 kW.
 ② Contact factory for other voltage options.
 ③ Voltage is listed at 60 Hz unless otherwise noted. Other voltages available upon request.
 ④ Select proper "XTOB" overload amperage range as per motor FLA, see **Page V10-T3-9**.
 ⑤ The catalog numbers listed in the Type 4X column are for Type 4X 304-Grade stainless steel, as indicated by the **seventh** digit.
 Example: ECX25M4AAA_-. To order Type 4X 316-Grade stainless steel, change that digit to **9**. To order Type 4 painted steel, change that digit to **3**.
 To order non-metallic, change that digit to **5**. For details on these alternate enclosures, see **Tab 13**.

3.1

IEC Contactors and Starters

XT IEC Power Control

3

Class ECX26—Combination Reversing Starter—Circuit Breaker

Amps	Maximum hp ^①		Coil Voltage at 60 Hz ^③	Circuit Breaker	Type 1/IP23 Catalog Number ^④	Type 4X/IP66 ^⑤ Catalog Number ^④	Type 12/IP65 Catalog Number ^④	Component	
	Motor Voltage ^②	Single-Phase						Three-Phase	Catalog Number ^④
Size B									
7	115	1/4	—	120	7 A	ECX26B1AAC_-	ECX26B4AAC_-	ECX26B8AAC_-	XTAR007B10A_
	208	3/4	1-1/2	208		ECX26B1EAC_-	ECX26B4EAC_-	ECX26B8EAC_-	XTAR007B10E_
	230	1	2	240		ECX26B1BAC_-	ECX26B4BAC_-	ECX26B8BAC_-	XTAR007B10B_
	380	—	3	380/50 Hz		ECX26B1LAC_-	ECX26B4LAC_-	ECX26B8LAC_-	XTAR007B10L_
	460	—	3	480		ECX26B1CAC_-	ECX26B4CAC_-	ECX26B8CAC_-	XTAR007B10C_
	575	—	5	600		ECX26B1DAC_-	ECX26B4DAC_-	ECX26B8DAC_-	XTAR007B10D_
	Size C								
9	115	1/2	—	120	15 A	ECX26C1AAD_-	ECX26C4AAD_-	ECX26C8AAD_-	XTAR009B10A_
	208	1	2	208		ECX26C1EAD_-	ECX26C4EAD_-	ECX26C8EAD_-	XTAR009B10E_
	230	1-1/2	3	240		ECX26C1BAD_-	ECX26C4BAD_-	ECX26C8BAD_-	XTAR009B10B_
	380	—	5	380/50 Hz		ECX26C1LAD_-	ECX26C4LAD_-	ECX26C8LAD_-	XTAR009B10L_
	460	—	5	480		ECX26C1CAD_-	ECX26C4CAD_-	ECX26C8CAD_-	XTAR009B10C_
	575	—	7-1/2	600		ECX26C1DAD_-	ECX26C4DAD_-	ECX26C8DAD_-	XTAR009B10D_
	Size D								
12	115	1/2	—	120	15 A	ECX26D1AAD_-	ECX26D4AAD_-	ECX26D8AAD_-	XTAR012B10A_
	208	1-1/2	3	208		ECX26D1EAD_-	ECX26D4EAD_-	ECX26D8EAD_-	XTAR012B10E_
	230	2	3	240		ECX26D1BAD_-	ECX26D4BAD_-	ECX26D8BAD_-	XTAR012B10B_
	380	—	5	380/50 Hz		ECX26D1LAD_-	ECX26D4LAD_-	ECX26D8LAD_-	XTAR012B10L_
	460	—	7-1/2	480		ECX26D1CAD_-	ECX26D4CAD_-	ECX26D8CAD_-	XTAR012B10C_
	575	—	10	600		ECX26D1DAD_-	ECX26D4DAD_-	ECX26D8DAD_-	XTAR012B10D_
	Size E								
15	115	3/4	—	120	30 A	ECX26E1AAE_-	ECX26E4AAE_-	ECX26E8AAE_-	XTAR015B10A_
	208	2	3	208		ECX26E1EAE_-	ECX26E4EAE_-	ECX26E8EAE_-	XTAR015B10E_
	230	2	3	240		ECX26E1BAE_-	ECX26E4BAE_-	ECX26E8BAE_-	XTAR015B10B_
	380	—	5	380/50 Hz		ECX26E1LAE_-	ECX26E4LAE_-	ECX26E8LAE_-	XTAR015B10L_
	460	—	7-1/2	480		ECX26E1CAE_-	ECX26E4CAE_-	ECX26E8CAE_-	XTAR015B10C_
	575	—	10	600		ECX26E1DAE_-	ECX26E4DAE_-	ECX26E8DAE_-	XTAR015B10D_
	Size F								
18	115	2	—	120	30 A	ECX26F1AAE_-	ECX26F4AAE_-	ECX26F8AAE_-	XTAR018C10A_
	208	2	5	208		ECX26F1EAE_-	ECX26F4EAE_-	ECX26F8EAE_-	XTAR018C10E_
	230	3	5	240		ECX26F1BAE_-	ECX26F4BAE_-	ECX26F8BAE_-	XTAR018C10B_
	380	—	7-1/2	380/50 Hz		ECX26F1LAE_-	ECX26F4LAE_-	ECX26F8LAE_-	XTAR018C10L_
	460	—	10	480		ECX26F1CAE_-	ECX26F4CAE_-	ECX26F8CAE_-	XTAR018C10C_
	575	—	15	600		ECX26F1DAE_-	ECX26F4DAE_-	ECX26F8DAE_-	XTAR018C10D_

Notes

- ① 1 hp = 0.746 kW.
- ② Contact factory for other voltage options.
- ③ Voltage is listed at 60 Hz unless otherwise noted. Other voltages available upon request.
- ④ Select proper "XTOB" overload amperage range as per motor FLA, see **Page V10-T3-9**.
- ⑤ The catalog numbers listed in the Type 4X column are for Type 4X 304-Grade stainless steel, as indicated by the **seventh** digit.
Example: ECX26B4AAA_- . To order Type 4X 316-Grade stainless steel, change that digit to **9**. To order Type 4 painted steel, change that digit to **3**.
To order non-metallic, change that digit to **5**. For details on these alternate enclosures, see **Tab 13**.

Class ECX26—Combination Reversing Starter—Circuit Breaker, continued

Amps	Maximum hp ^①		Coil Voltage at 60 Hz ^③	Circuit Breaker	Type 1/IP23 Catalog Number ^④	Type 4X/IP66 ^⑤ Catalog Number ^④	Type 12/IP65 Catalog Number ^④	Component Catalog Number ^④	
	Motor Voltage ^②	Single-Phase							Three-Phase
Size G									
25	115	2	—	120	50 A	ECX26G1AAF_-	ECX26G4AAF_-	ECX26G8AAF_-	XTAR025C10A_
	208	3	7-1/2	208		ECX26G1EAF_-	ECX26G4EAF_-	ECX26G8EAF_-	XTAR025C10E_
	230	5	7-1/2	240		ECX26G1BAF_-	ECX26G4BAF_-	ECX26G8BAF_-	XTAR025C10B_
	380	—	10	380/50 Hz		ECX26G1LAF_-	ECX26G4LAF_-	ECX26G8LAF_-	XTAR025C10L_
	460	—	15	480		ECX26G1CAF_-	ECX26G4CAF_-	ECX26G8CAF_-	XTAR025C10C_
	575	—	20	600		ECX26G1DAF_-	ECX26G4DAF_-	ECX26G8DAF_-	XTAR025C10D_
Size H									
32	115	3	—	120	50 A	ECX26H1AAF_-	ECX26H4AAF_-	ECX26H8AAF_-	XTAR032C10A_
	208	5	10	208		ECX26H1EAF_-	ECX26H4EAF_-	ECX26H8EAF_-	XTAR032C10E_
	230	5	10	240		ECX26H1BAF_-	ECX26H4BAF_-	ECX26H8BAF_-	XTAR032C10B_
	380	—	15	380/50 Hz		ECX26H1LAF_-	ECX26H4LAF_-	ECX26H8LAF_-	XTAR032C10L_
	460	—	20	480		ECX26H1CAF_-	ECX26H4CAF_-	ECX26H8CAF_-	XTAR032C10C_
	575	—	25	600		ECX26H1DAF_-	ECX26H4DAF_-	ECX26H8DAF_-	XTAR032C10D_
Size J									
40	115	3	—	120	50 A	ECX26J1AAF_-	ECX26J4AAF_-	ECX26J8AAF_-	XTAR040D00A_
	208	5	10	208		ECX26J1EAF_-	ECX26J4EAF_-	ECX26J8EAF_-	XTAR040D00E_
	230	7-1/2	15	240		ECX26J1BAF_-	ECX26J4BAF_-	ECX26J8BAF_-	XTAR040D00B_
	380	—	15	380/50 Hz		ECX26J1LAF_-	ECX26J4LAF_-	ECX26J8LAF_-	XTAR040D00L_
	460	—	30	480		ECX26J1CAF_-	ECX26J4CAF_-	ECX26J8CAF_-	XTAR040D00C_
	575	—	40	600		ECX26J1DAF_-	ECX26J4DAF_-	ECX26J8DAF_-	XTAR040D00D_
Size K									
50	115	3	—	120	70 A	ECX26K1AAW_-	ECX26K4AAW_-	ECX26K8AAW_-	XTAR050D00A_
	208	7-1/2	15	208		ECX26K1EAW_-	ECX26K4EAW_-	ECX26K8EAW_-	XTAR050D00E_
	230	10	20	240		ECX26K1BAW_-	ECX26K4BAW_-	ECX26K8BAW_-	XTAR050D00B_
	380	—	20	380/50 Hz		ECX26K1LAW_-	ECX26K4LAW_-	ECX26K8LAW_-	XTAR050D00L_
	460	—	40	480		ECX26K1CAW_-	ECX26K4CAW_-	ECX26K8CAW_-	XTAR050D00C_
	575	—	50	600		ECX26K1DAW_-	ECX26K4DAW_-	ECX26K8DAW_-	XTAR050D00D_
Size L									
65	115	5	—	120	100 A	ECX26L1AAW_-	ECX26L4AAW_-	ECX26L8AAW_-	XTAR065D00A_
	208	10	20	208		ECX26L1EAW_-	ECX26L4EAW_-	ECX26L8EAW_-	XTAR065D00E_
	230	15	25	240		ECX26L1BAW_-	ECX26L4BAW_-	ECX26L8BAW_-	XTAR065D00B_
	380	—	30	380/50 Hz		ECX26L1LAW_-	ECX26L4LAW_-	ECX26L8LAW_-	XTAR065D00L_
	460	—	50	480		ECX26L1CAW_-	ECX26L4CAW_-	ECX26L8CAW_-	XTAR065D00C_
	575	—	60	600		ECX26L1DAW_-	ECX26L4DAW_-	ECX26L8DAW_-	XTAR065D00D_

Notes

- ① 1 hp = 0.746 kW.
 ② Contact factory for other voltage options.
 ③ Voltage is listed at 60 Hz unless otherwise noted. Other voltages available upon request.
 ④ Select proper "XTOB" overload amperage range as per motor FLA, see **Page V10-T3-9**.
 ⑤ The catalog numbers listed in the Type 4X column are for Type 4X 304-Grade stainless steel, as indicated by the **seventh** digit.
 Example: ECX26G4AAF_- . To order Type 4X 316-Grade stainless steel, change that digit to **9**. To order Type 4 painted steel, change that digit to **3**.
 To order non-metallic, change that digit to **5**. For details on these alternate enclosures, see **Tab 13**.

3.1

IEC Contactors and Starters

XT IEC Power Control

3

Class ECX26—Combination Reversing Starter—Circuit Breaker, continued

Amps	Maximum hp ^①		Coil Voltage at 60 Hz ^③	Circuit Breaker	Type 1/IP23 Catalog Number ^④	Type 4X/IP66 ^⑤ Catalog Number ^④	Type 12/IP65 Catalog Number ^④	Component	
	Motor Voltage ^②	Single-Phase						Three-Phase	Catalog Number ^④
Size M									
80	115	7-1/2	—	120	100 A	ECX26M1AAG_-	ECX26M4AAG_-	ECX26M8AAG_-	XTAR080F00A_
	208	15	25	208		ECX26M1EAG_-	ECX26M4EAG_-	ECX26M8EAG_-	XTAR080F00E_
	230	15	30	240		ECX26M1BAG_-	ECX26M4BAG_-	ECX26M8BAG_-	XTAR080F00B_
	380	—	50	380/50 Hz		ECX26M1LAG_-	ECX26M4LAG_-	ECX26M8LAG_-	XTAR080F00L_
	460	—	60	480		ECX26M1CAG_-	ECX26M4CAG_-	ECX26M8CAG_-	XTAR080F00C_
	575	—	75	600		ECX26M1DAG_-	ECX26M4DAG_-	ECX26M8DAG_-	XTAR080F00D_
Size N									
95	115	7-1/2	—	120	100 A	ECX26N1AAG_-	ECX26N4AAG_-	ECX26N8AAG_-	XTAR095F00A_
	208	15	25	208		ECX26N1EAG_-	ECX26N4EAG_-	ECX26N8EAG_-	XTAR095F00E_
	230	15	40	240		ECX26N1BAG_-	ECX26N4BAG_-	ECX26N8BAG_-	XTAR095F00B_
	380	—	60	380/50 Hz		ECX26N1LAG_-	ECX26N4LAG_-	ECX26N8LAG_-	XTAR095F00L_
	460	—	75	480		ECX26N1CAG_-	ECX26N4CAG_-	ECX26N8CAG_-	XTAR095F00C_
	575	—	100	600		ECX26N1DAG_-	ECX26N4DAG_-	ECX26N8DAG_-	XTAR095F00D_
Size P									
115	115	10	—	120	150 A	ECX26P1AAH_-	ECX26P4AAH_-	ECX26P8AAH_-	XTAR115G00A_
	208	25	40	208		ECX26P1EAH_-	ECX26P4EAH_-	ECX26P8EAH_-	XTAR115G00E_
	230	25	50	240		ECX26P1BAH_-	ECX26P4BAH_-	ECX26P8BAH_-	XTAR115G00B_
	380	—	60	380/50 Hz		ECX26P1LAH_-	ECX26P4LAH_-	ECX26P8LAH_-	XTAR115G00L_
	460	—	100	480		ECX26P1CAH_-	ECX26P4CAH_-	ECX26P8CAH_-	XTAR115G00C_
	575	—	125	600		ECX26P1DAH_-	ECX26P4DAH_-	ECX26P8DAH_-	XTAR115G00D_

Notes

- ① 1 hp = 0.746 kW.
- ② Contact factory for other voltage options.
- ③ Voltage is listed at 60 Hz unless otherwise noted. Other voltages available upon request.
- ④ Select proper "XTOB" overload amperage range as per motor FLA, see **Page V10-T3-9**.
- ⑤ The catalog numbers listed in the Type 4X column are for Type 4X 304-Grade stainless steel, as indicated by the **seventh** digit. Example: ECX26M4AAG_-. To order Type 4X 316-Grade stainless steel, change that digit to **9**. To order Type 4 painted steel, change that digit to **3**. To order non-metallic, change that digit to **5**. For details on these alternate enclosures, see **Tab 13**.

Wiring Diagrams

Typical Wiring Diagram

FVNR with Pushbutton Control

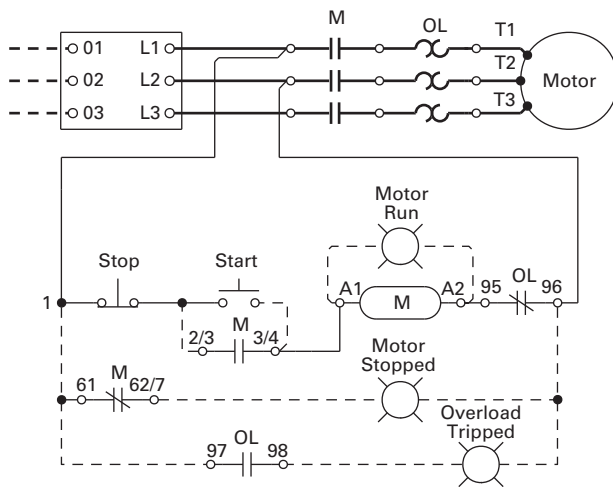

With Three-Position Selector Switch

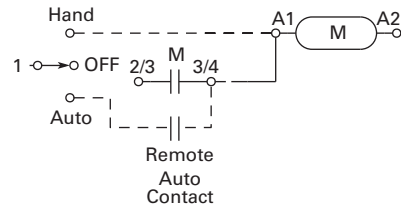

Control Power Transformer Option

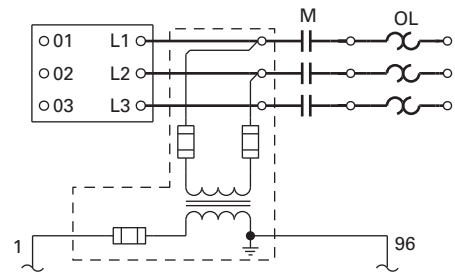

Reversing Combination Starter Wiring

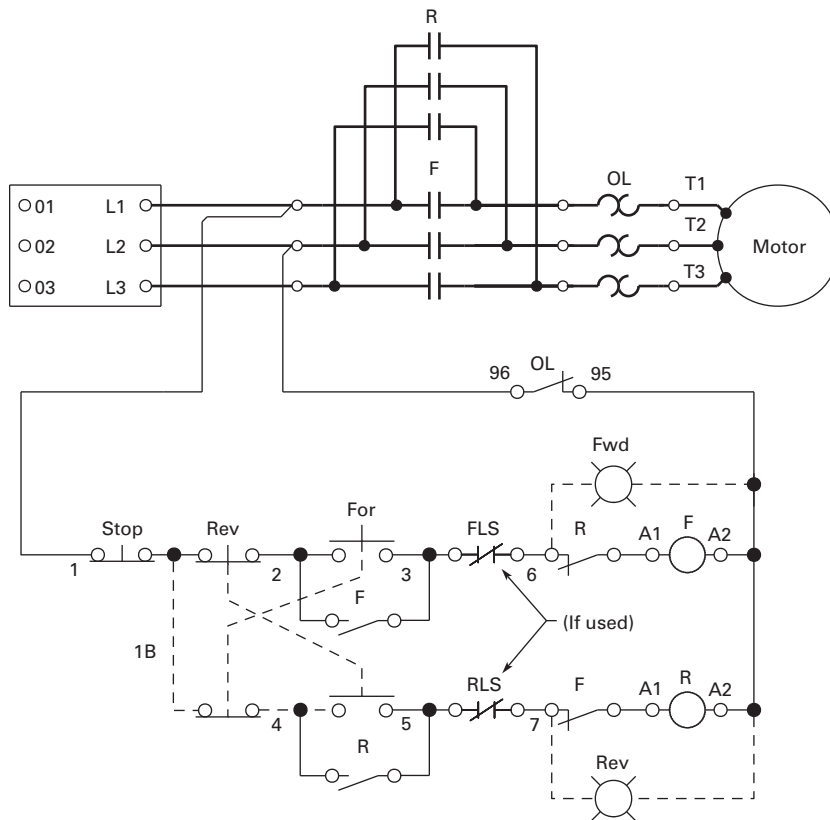

Three-Position Switch

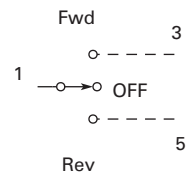

Two- and Three-Position Switch

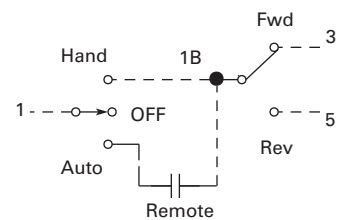

3.1

IEC Contactors and Starters

XT IEC Power Control

3

Non-Combination Starters (Non-Reversing)

Remote Pilot Devices

Two-Wire Control

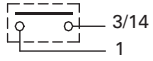

Not for Use with Auto Reset OL Relays

Three-Wire Control

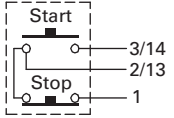

When More than One Pushbutton Station is Used, Omit Connector "A" and Connect per Sketch Below

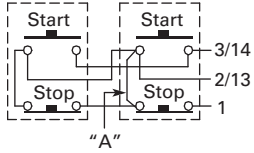

Connections for Non-Reversing Starter

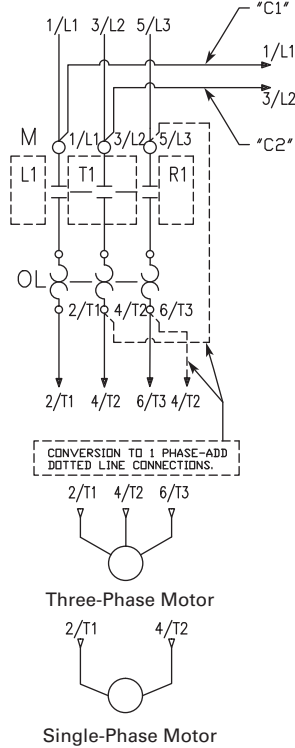

Non-Combination Starters (Reversing)

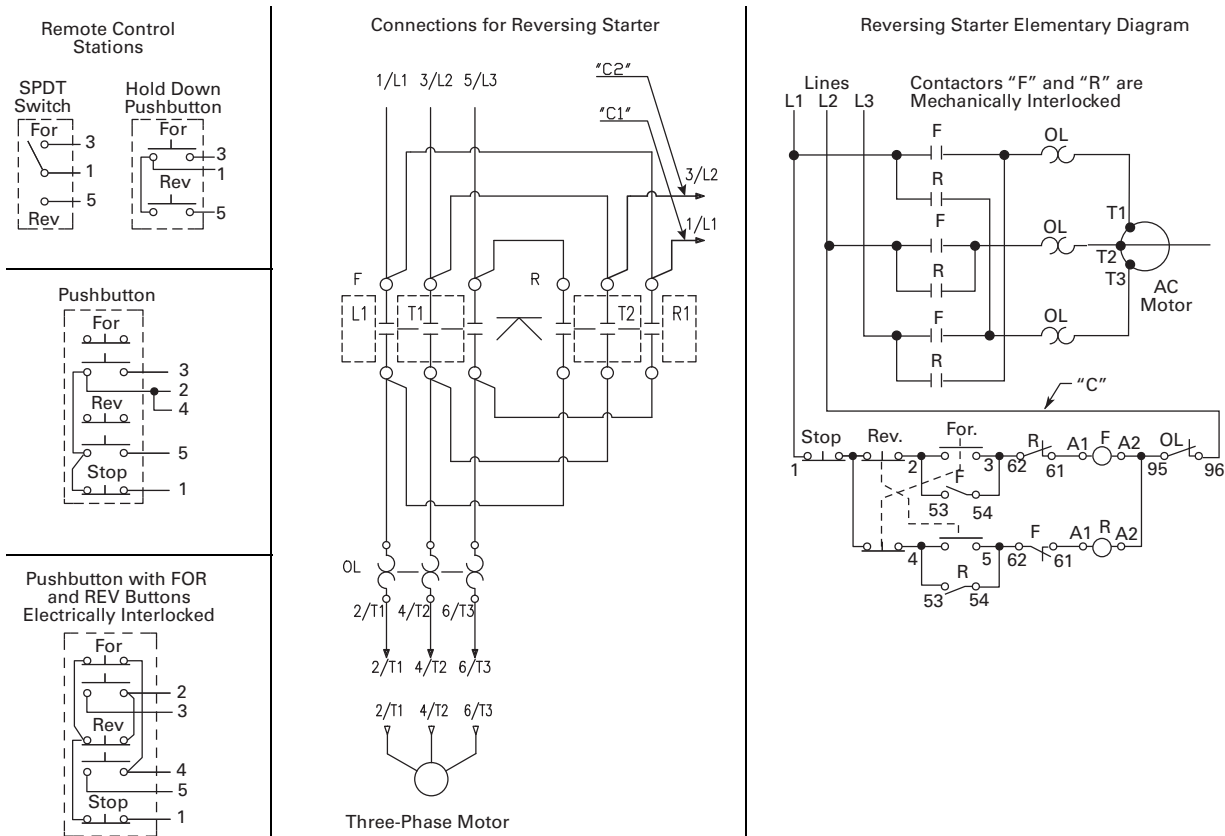

C400T Control Options

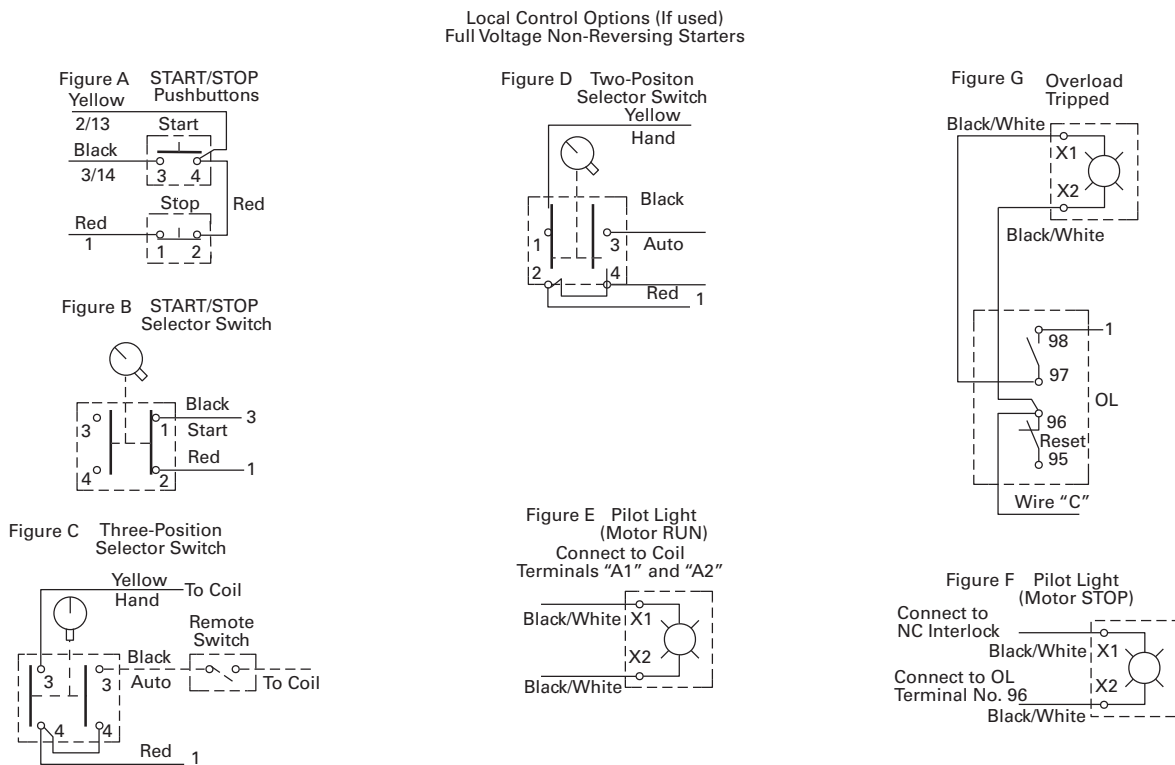

Local Control Options (If used)
Full Voltage Non-Reversing Starters

Figure E Pilot Light (Motor RUN)
Connect to Coil
Terminals "A1" and "A2"

Figure F Pilot Light (Motor STOP)
Connect to
NC Interlock
Black/White X1
Connect to OL
Terminal No. 96
Black/White X2

3.1

IEC Contactors and Starters

XT IEC Power Control

Non-Reversing Cover Control

Type 1 C600M Control Options (To be used with Box 1 Only)

3

Connections for Non-Reversing Starter

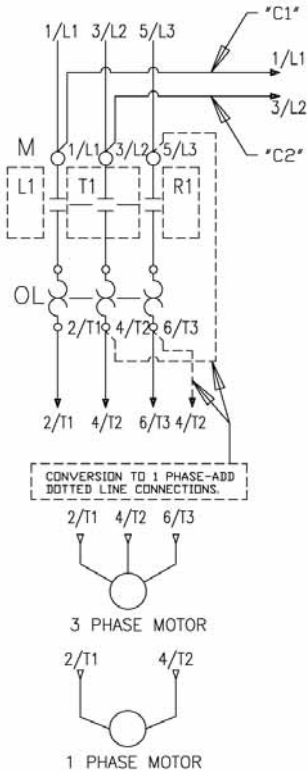

Schematic Symbol Legend

	Normally Open Auxiliary
	Normally Closed Auxiliary
	Normally Open Momentary PB
	Normally Closed Momentary PB
	Contactor Coil
	Red Pilot Light
	Green Pilot Light
	Normally Closed Overload Auxiliary
	Normally Open Overload Auxiliary
	M22-XLED230-T: Used to lower voltage for pilot lights.
	Two-position selector switch (STOP/START, OFF/ON)
	Three-position selector switch (HOA)
	Signifies Location of Side and Top Adder Auxiliary Referenced on Diagram Under Auxiliary Symbol

CAUTION

READ AND FOLLOW INSTRUCTIONS PRIOR TO WIRING OR CONNECTING POWER! THIS PRODUCT CAN BE FACTORY OR FIELD CONFIGURED FOR MULTIPLE CONTROL MODES OR CONTROL VOLTAGES. CHECK NAMEPLATE FOR COIL VOLTAGE.

SEPARATE CONTROL POWER

FOR COIL VOLTAGES 120V AND LESS: CONNECT SEPARATE CONTROL LINES TO THE NO. 61 TERMINAL ON THE TOP ADDER AUX. AND TO THE NO. 96 TERMINAL ON THE OVERLOAD RELAY.

FOR COIL VOLTAGES GREATER THAN 120V: REMOVE WIRE "C2" IF SUPPLIED. IF WIRE "C1" IS TERMINATED ON L1, DISCONNECT FROM L1. CONNECT SEPARATE CONTROL LINES TO THE "C1" WIRE OR APPROPRIATE PILOT DEVICE TERMINAL PER DIAGRAM AND TO THE NO. 96 TERMINAL ON THE OVERLOAD RELAY.

COMMON CONTROL POWER

FOR COIL VOLTAGES 120V AND LESS: ADD WIRE "C2" IF NOT SUPPLIED. ADD CONNECTOR BETWEEN L1 TERMINAL AND THE NO. 61 TERMINAL ON THE TOP ADDER AUX. OR APPROPRIATE PILOT DEVICE TERMINAL PER DIAGRAM.

FOR COIL VOLTAGES GREATER THAN 120V: ADD WIRE "C1" AND "C2" IF NOT SUPPLIED.

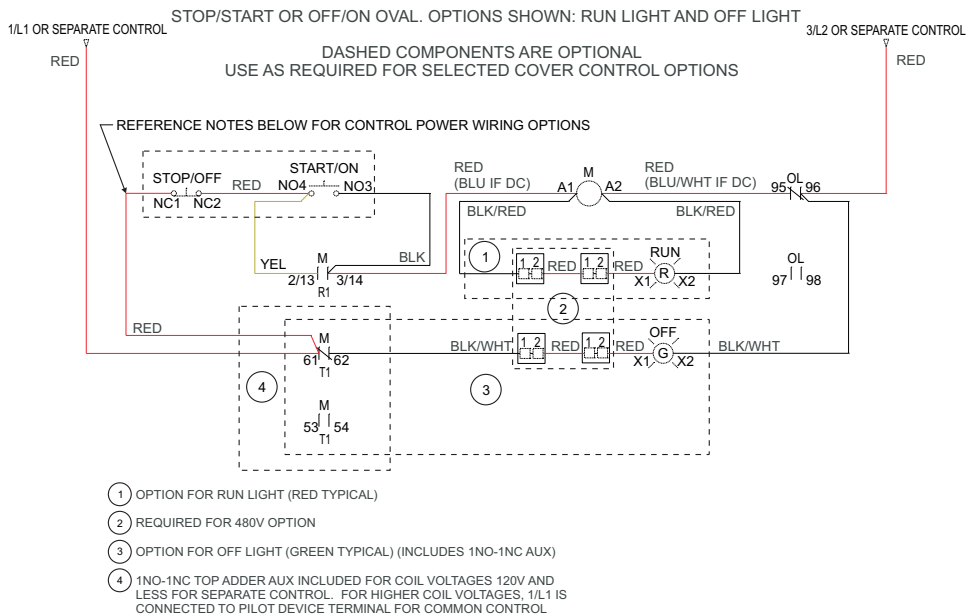

Type 1 C600M Control Options (To be used with Box 1 Only)

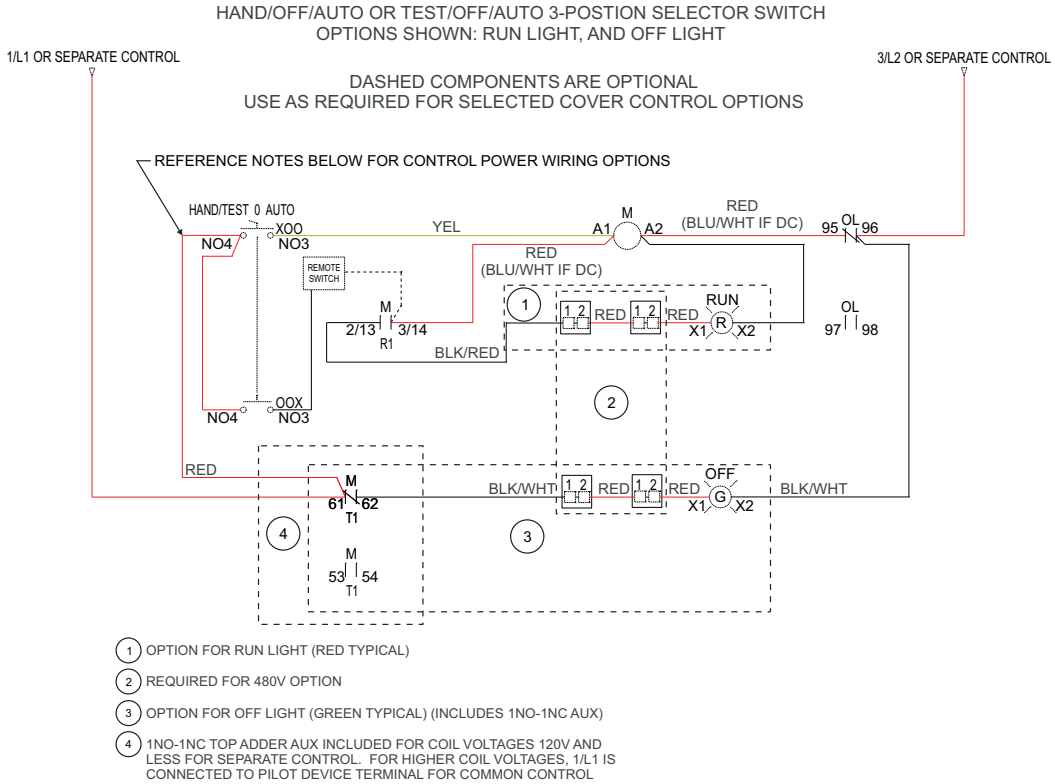
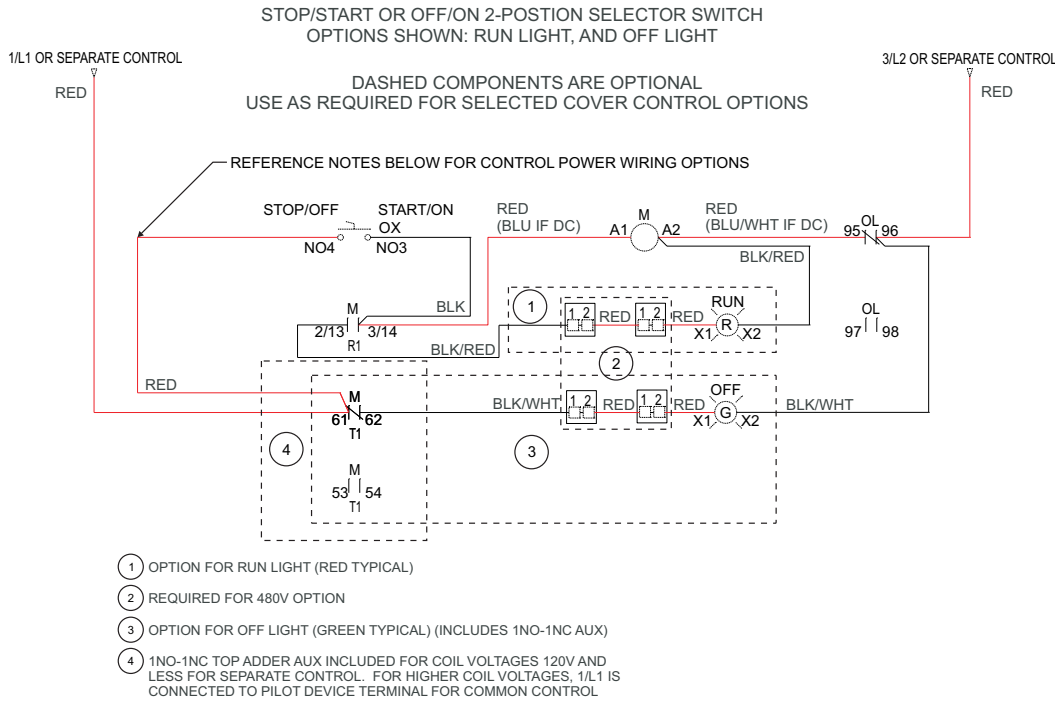

3.1

IEC Contactors and Starters

X7 IEC Power Control

3

Type 1 C600M Control Options (To be used with Box 1 Only)

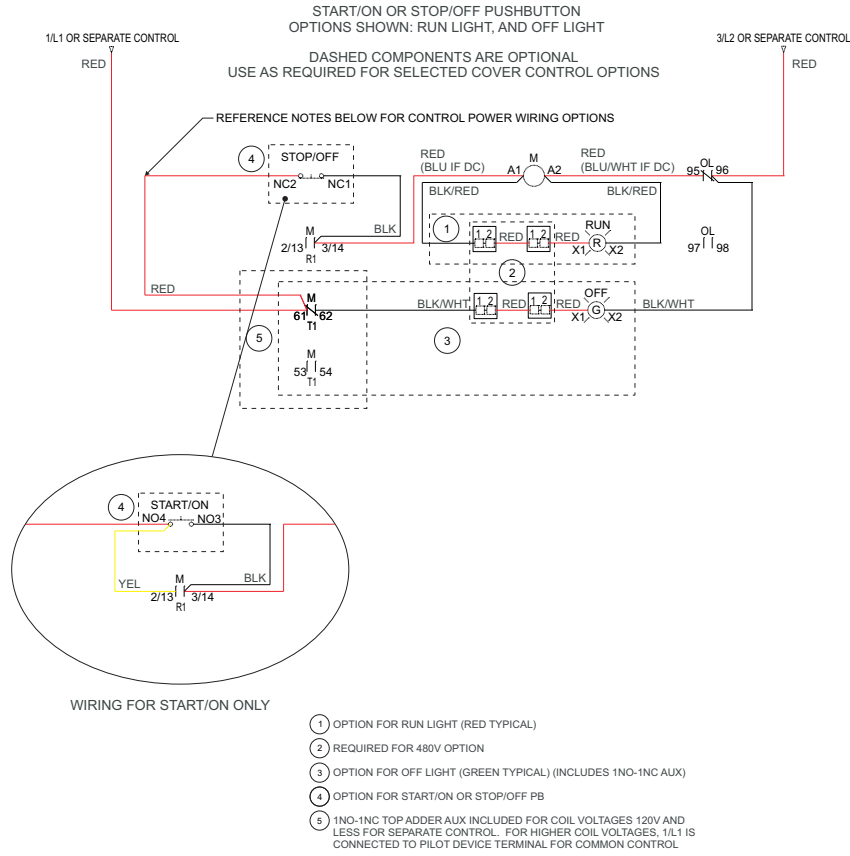

Reversing Cover Control

Type 1 C600M Control Options (To be used with Box 1 Only)

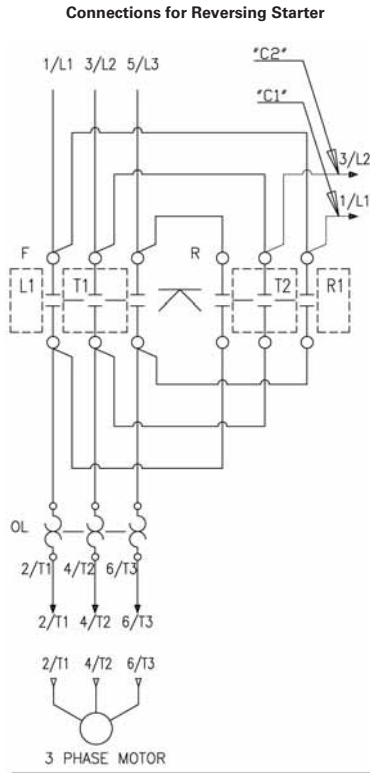

Schematic Symbol Legend

	2/13 3/14	Normally Open Auxiliary
	61 62	Normally Closed Auxiliary
	NO4 NO3	Normally Open Momentary PB
	NC1 NC2	Normally Closed Momentary PB
	A1 A2	Contactor Coil
	X1 X2	Red Pilot Light
	X1 X2	Green Pilot Light
	95 96	Normally Closed Overload Auxiliary
	97 98	Normally Open Overload Auxiliary
	1 2	M22-XLED230-T: Used to lower voltage for pilot lights.
	NO4 NO3	Two-position selector switch (STOP/START, OFF/ON)
	NO4 NO3	Three-position selector switch (HOA)
		Signifies Location of Side and Top Adder Auxiliary Referenced on Diagram Under Auxiliary Symbol

CAUTION
 READ AND FOLLOW INSTRUCTIONS PRIOR TO WIRING OR CONNECTING POWER!
 THIS PRODUCT CAN BE FACTORY OR FIELD CONFIGURED FOR MULTIPLE CONTROL MODES OR CONTROL VOLTAGES. CHECK NAMEPLATE FOR COIL VOLTAGE.

SEPARATE CONTROL POWER
 FOR COIL VOLTAGES 120V AND LESS: CONNECT SEPARATE CONTROL LINES TO THE NO. 63 OR NO. 61 TERMINAL PER DIAGRAM ON THE TOP ADDER AUX. AND TO THE NO. 96 TERMINAL ON THE OVERLOAD RELAY.
 FOR COIL VOLTAGES GREATER THAN 120V: REMOVE WIRE "C2" IF SUPPLIED. IF WIRE "C1" IS TERMINATED ON L1, DISCONNECT FROM L1. CONNECT SEPARATE CONTROL LINES TO THE "C1" WIRE OR APPROPRIATE PILOT DEVICE TERMINAL PER DIAGRAM AND TO THE NO. 96 TERMINAL ON THE OVERLOAD RELAY.

COMMON CONTROL POWER
 FOR COIL VOLTAGES 120V AND LESS: ADD WIRE "C2" IF NOT SUPPLIED. ADD CONNECTOR BETWEEN L1 TERMINAL AND THE NO. 61 OR NO. 63 TERMINAL PER DIAGRAM ON THE TOP ADDER AUX. OR APPROPRIATE PILOT DEVICE TERMINAL PER DIAGRAM.
 FOR COIL VOLTAGES GREATER THAN 120V: ADD WIRE "C1" AND "C2" IF NOT SUPPLIED.

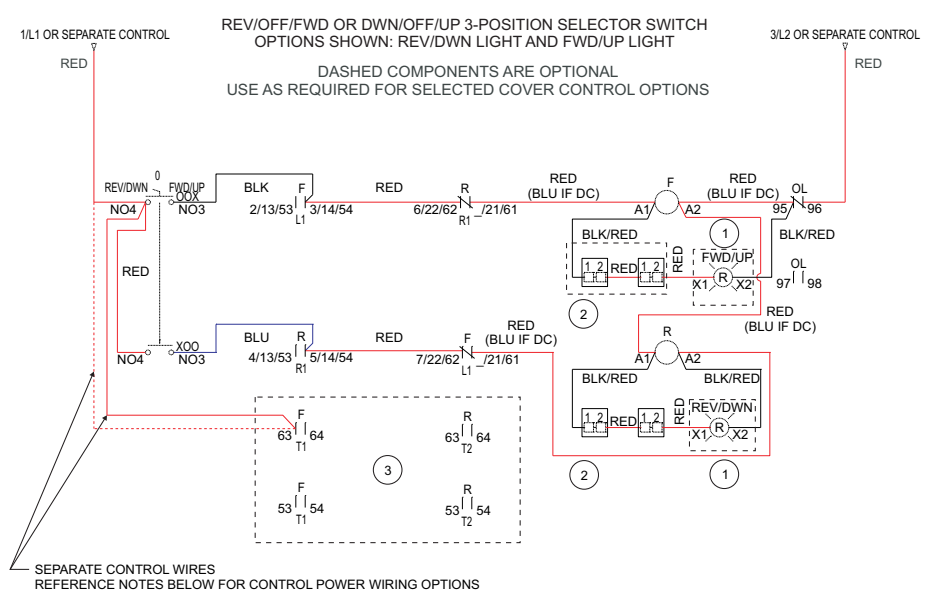

- ① OPTION FOR RUN LIGHT (RED TYPICAL)
- ② REQUIRED FOR 480V OPTION
- ③ TWO 2NO TOP ADDER AUX INCLUDED FOR ALL COIL VOLTAGES. WHEN COIL VOLTAGES 120V AND LESS, CONTROL WIRING ROUTED TO NO. 63 TERMINAL FOR SEPARATE CONTROL.

Enclosed XT Combination Motor Controller

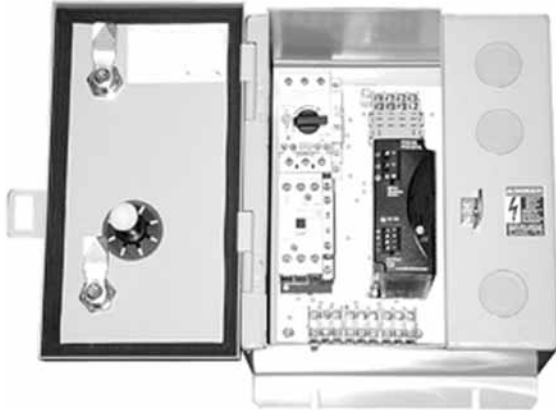

Contents

Description	Page
Non-Metallic Enclosure—Contactors and Starters . . .	V10-T3-2
Metallic Enclosure—Contactors and Starters	V10-T3-8
Combination Motor Controllers	
Catalog Number Selection	V10-T3-44
Cover Control	V10-T3-45
Product Selection	
Non-Reversing Starters	V10-T3-46
Non-Reversing Starters with CPT	V10-T3-46
Reversing Starters	V10-T3-47

Combination Motor Controllers

Product Description

Eaton's **XT** line includes IEC contactors, starters and combination motor controllers (CMCs). Designed to meet international standards, the enclosed control **XT** line (ECX), carries UL and cUL certifications.

Features and Benefits

- ON/OFF rotary handle with lockout provision
- Visible trip indication
- Test trip function
- Motor applications from 0.11 A to 32 A
- Class 10 overload protection
- Built-in heater and magnetic trip elements to protect the motor
- Phase loss sensitivity
- Type 2 coordination
- Ambient compensated up to 55 °C [140 °F]
- Control inputs located at front of starter for easy access and wiring
- Wide range of coils
- DIN rail mount—XTSC...BB_
- Mounting plates—XTSC...BC_, XTSC...D motor controllers
- Adjustment dial for setting motor FLA
- Short-circuit trip at 14 times the maximum setting of the FLA adjustment dial
- UL 508 Type F CMC high fault short-circuit ratings; refer to manual motor protectors in **CA08102001E**
- Non-metallic and metallic enclosures in Types 1 (IP23), 4 (IP66), 4X (IP66) and 12 (IP65)
- Opaque (standard) or clear covers available on non-metallic Halyester enclosure

Standards and Certifications

Note: See **Tab 17** for additional information on standards and certifications that apply to all enclosed control products.

- UL Listed
- cUL Listed (indicates appropriate CSA Standard investigation)

Short-Circuit Ratings

- 0–12 A / B-frame MMP with B-frame contactor
 - 50K AIC at 600 V
- 13–32A/B-frame MMP with C-frame contactor
 - 18K AIC at 600 V

Additional Reference

Dimensions	Tab 14
Accessories and Modifications	Tab 15
Renewal Parts	Tab 16
Technical Data and Specifications	Tab 17

3.1

IEC Contactors and Starters

X^T IEC Power Control

Catalog Number Selection

Combination Motor Controllers—Enclosed Control

3

EC X 76 D 4 B A A -

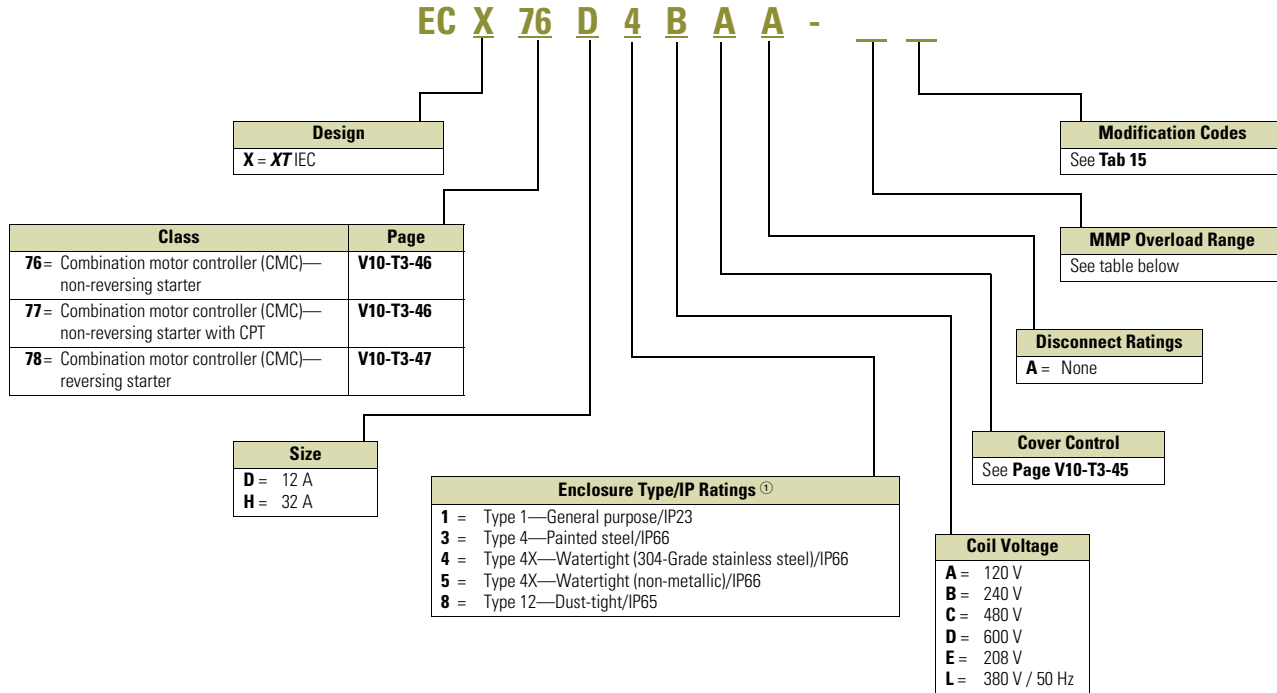

XTPR MMP Amperage Ranges

XT MMP Catalog Number	Overload Amp Range	Enclosed Control Suffix Code
Frame B Rotary MMP		
XTPRP16BC1	0.1–0.16	A
XTPRP25BC1	0.16–0.25	B
XTPRP40BC1	0.25–0.4	C
XTPRP63BC1	0.4–0.63	D
XTPR01BC1	0.63–1	E
XTPR1P6BC1	1–1.6	F
XTPR2P5BC1	1.6–2.5	G
XTPR04BC1	2.5–4	H
XTPR6P3BC1	4–6.3	J
XTPR010BC1	6.3–10	K
XTPR012BC1	8–12.0	L
XTPR016BC1	10–16.0	M
XTPR020BC1	16–20	N
XTPR025BC1	20–25	Q
XTPR032BC1	25–32	R

Note

① See Tab 1 for enclosure type/IP rating cross-reference.

Cover Control

- Cover control for combination motor control starters uses the 10250T (30 mm) family
- Selector switches are maintained with lever operators
- Pushbuttons are momentary type with extended pushbutton
- The kit includes hardware and connecting wires (where possible)
- For factory installed control devices other than shown below, refer to modification codes, **Tab 15**

Product Selection**10250T Style Combination Cover Control**

Description	Factory Installed	Field Installation
	Flange Control	Kits
	Position 9 Alpha	Combination Catalog Number
Non-Reversing		
No cover mounted pilot devices	A	—
START/STOP pushbuttons	B	C400T1
With red RUN pilot light	C	—
With red RUN/green OFF lights	D	—
ON/OFF pushbuttons	E	C400T2
With red RUN pilot light	F	—
With red RUN/green OFF lights	G	—
HAND/OFF/AUTO selector switch	H	C400T12
With red RUN pilot light	J	—
With red RUN/green OFF lights	K	—
START pushbutton	L	C400T3
ON pushbutton	M	C400T4
OFF pushbutton	N	C400T5
Red RUN pilot light	P	C400T9 ^①
Green OFF	Q	C400T10 ^①
Red RUN/green OFF pilot lights	R	C400T11 ^①
START/STOP selector switch	S	C400T13
With red RUN pilot light	T	—
With red RUN/green OFF lights	U	—
ON/OFF selector switch	V	C400T14
With red RUN pilot light	W	—
With red RUN/green OFF lights	X	—

Notes

^① Add code letter from the table below to catalog number for voltage—kits only. Example: C400T9**B**.

Rating	Code Letter	Rating	Code Letter	Rating	Code Letter
120 V 60 Hz	A	240 V 60 Hz	B	480 V 60 Hz	C
208 V 60 Hz	E	380 V 50 Hz	L	600 V 60 Hz	D

^② Order quantity (2) of **C400T10**.

Description	Factory Installed	Field Installation
	Flange Control	Kits
	Position 9 Alpha	Combination Catalog Number
Reversing		
No cover mounted pilot devices	A	—
FOR/REV/STOP pushbuttons	B	C400T6
With two red pilot lights	C	—
With two red/one green pilot lights	D	—
UP/STOP/DOWN pushbuttons	E	—
With two red pilot lights	F	—
FOR/OFF/REV selector switch	H	C400T15
With two red pilot lights	J	—
With two red/one green pilot lights	K	—
Two red pilot lights	P	^②
One green pilot light	Q	C400T10 ^①
Two red/one green pilot lights	R	—
OPEN/OFF/CLOSE selector switch	V	C400T16
With two red pilot lights	W	—
With two red/one green pilot lights	X	—

3.1

IEC Contactors and Starters

XT IEC Power Control

Product Selection

Non-Reversing Starters

Class ECX76—Combination Motor Controller (CMC)—Non-Reversing Starter

Amps	Maximum hp ^①			Coil Voltage at 60 Hz ^②	Type 1/IP23	Type 4X/IP66 ^{③④}	Type 4X	Type 12/IP65	Component ^⑤
	Motor Voltage	Single-Phase	Three-Phase		General Purpose	Watertight	Non-Metallic/IP66	Dust-Tight	
					Catalog Number	Catalog Number	Catalog Number	Catalog Number	Catalog Number
Size D									
12	115	1/2	—	120	ECX76D1AAA-	ECX76D4AAA-	ECX76D5AAA-	ECX76D8AAA-	XTPR__BC1
	208	1-1/2	3	208	ECX76D1EAA-	ECX76D4EAA-	ECX76D5EAA-	ECX76D8EAA-	
	230	2	3	240	ECX76D1BAA-	ECX76D4BAA-	ECX76D5BAA-	ECX76D8BAA-	
	380	—	5	380/50 Hz	ECX76D1LAA-	ECX76D4LAA-	ECX76D5LAA-	ECX76D8LAA-	
	460	—	7-1/2	480	ECX76D1CAA-	ECX76D4CAA-	ECX76D5CAA-	ECX76D8CAA-	
	575	—	10	600	ECX76D1DAA-	ECX76D4DAA-	ECX76D5DAA-	ECX76D8DAA-	
Size H									
32	115	3	—	120	ECX76H1AAA-	ECX76H4AAA-	ECX76H5AAA-	ECX76H8AAA-	XTPR__BC1
	208	5	10	208	ECX76H1EAA-	ECX76H4EAA-	ECX76H5EAA-	ECX76H8EAA-	
	230	5	10	240	ECX76H1BAA-	ECX76H4BAA-	ECX76H5BAA-	ECX76H8BAA-	
	380	—	15	380/50 Hz	ECX76H1LAA-	ECX76H4LAA-	ECX76H5LAA-	ECX76H8LAA-	
	460	—	20	480	ECX76H1CAA-	ECX76H4CAA-	ECX76H5CAA-	ECX76H8CAA-	
	575	—	25	600	ECX76H1DAA-	ECX76H4DAA-	ECX76H5DAA-	ECX76H8DAA-	

Non-Reversing Starters with CPT

Class ECX77—Combination Motor Controller (CMC)—Non-Reversing Starter with CPT

Amps	Maximum hp ^①			Coil Voltage at 60 Hz ^②	Type 1/IP23	Type 4X/IP66 ^{③④}	Type 4X	Type 12/IP65	Component ^⑤
	Motor Voltage	Single-Phase	Three-Phase		General Purpose	Watertight	Non-Metallic/IP66	Dust-Tight	
					Catalog Number	Catalog Number	Catalog Number	Catalog Number	Catalog Number
Size D									
12	115	1/2	—	120	ECX77D1AAA-	ECX77D4AAA-	ECX77D5AAA-	ECX77D8AAA-	XTPR__BC1
	208	1-1/2	3	208	ECX77D1EAA-	ECX77D4EAA-	ECX77D5EAA-	ECX77D8EAA-	
	230	2	3	240	ECX77D1BAA-	ECX77D4BAA-	ECX77D5BAA-	ECX77D8BAA-	
	380	—	5	380/50 Hz	ECX77D1LAA-	ECX77D4LAA-	ECX77D5LAA-	ECX77D8LAA-	
	460	—	7-1/2	480	ECX77D1CAA-	ECX77D4CAA-	ECX77D5CAA-	ECX77D8CAA-	
	575	—	10	600	ECX77D1DAA-	ECX77D4DAA-	ECX77D5DAA-	ECX77D8DAA-	
Size H									
32	115	3	—	120	ECX77H1AAA-	ECX77H4AAA-	ECX77H5AAA-	ECX77H8AAA-	XTPR__BC1
	208	5	10	208	ECX77H1EAA-	ECX77H4EAA-	ECX77H5EAA-	ECX77H8EAA-	
	230	5	10	240	ECX77H1BAA-	ECX77H4BAA-	ECX77H5BAA-	ECX77H8BAA-	
	380	—	15	380/50 Hz	ECX77H1LAA-	ECX77H4LAA-	ECX77H5LAA-	ECX77H8LAA-	
	460	—	20	480	ECX77H1CAA-	ECX77H4CAA-	ECX77H5CAA-	ECX77H8CAA-	
	575	—	25	600	ECX77H1DAA-	ECX77H4DAA-	ECX77H5DAA-	ECX77H8DAA-	

Notes

- ① 1 hp = 0.746 kW.
- ② Voltage is listed at 60 Hz unless otherwise noted. Other voltages available upon request.
- ③ The catalog numbers listed in the Type 4X column are for Type 4X 304-Grade stainless steel, as indicated by the **seventh** digit. Example: ECX76D5AAA-. To order Type 4 painted steel, change that digit to **3**.
- ④ Handle mechanism is rated Type 1 or 12. Contact local sales office for availability of Type 4X versions.
- ⑤ Select proper "XTPR" MMP overload amperage range as per motor FLA, see **Page V10-T3-44**.

Reversing Starters**Class ECX78—Combination Motor Controller (CMC)—Reversing Starter**

Amps	Maximum hp ^①			Coil Voltage at 60 Hz ^②	Type 1/IP23 General Purpose	Type 4X/IP66 ^{③④} Watertight	Type 4X Non-Metallic/IP66 Watertight ^④	Type 12/IP65 Dust-Tight	Component ^⑤
	Motor Voltage	Single-phase	Three-phase		Catalog Number	Catalog Number	Catalog Number	Catalog Number	Catalog Number
Size D									
12	115	1/2	—	120	ECX78D1AAA- __	ECX78D4AAA- __	ECX78D5AAA- __	ECX78D8AAA- __	XTPR- __ -BC1
	208	1-1/2	3	208	ECX78D1EAA- __	ECX78D4EAA- __	ECX78D5EAA- __	ECX78D8EAA- __	
	230	2	3	240	ECX78D1BAA- __	ECX78D4BAA- __	ECX78D5BAA- __	ECX78D8BAA- __	
	380	—	5	380/50 Hz	ECX78D1LAA- __	ECX78D4LAA- __	ECX78D5LAA- __	ECX78D8LAA- __	
	460	—	7-1/2	480	ECX78D1CAA- __	ECX78D4CAA- __	ECX78D5CAA- __	ECX78D8CAA- __	
	575	—	10	600	ECX78D1DAA- __	ECX78D4DAA- __	ECX78D5DAA- __	ECX78D8DAA- __	
Size H									
32	115	3	—	120	ECX78H1AAA- __	ECX78H4AAA- __	ECX78H5AAA- __	ECX78H8AAA- __	XTPR- __ -BC1
	208	5	10	208	ECX78H1EAA- __	ECX78H4EAA- __	ECX78H5EAA- __	ECX78H8EAA- __	
	230	5	10	240	ECX78H1BAA- __	ECX78H4BAA- __	ECX78H5BAA- __	ECX78H8BAA- __	
	380	—	15	380/50 Hz	ECX78H1LAA- __	ECX78H4LAA- __	ECX78H5LAA- __	ECX78H8LAA- __	
	460	—	20	480	ECX78H1CAA- __	ECX78H4CAA- __	ECX78H5CAA- __	ECX78H8CAA- __	
	575	—	25	600	ECX78H1DAA- __	ECX78H4DAA- __	ECX78H5DAA- __	ECX78H8DAA- __	

Notes

- ① 1 hp = 0.746 kW.
- ② Voltage is listed at 60 Hz unless otherwise noted. Other voltages available upon request.
- ③ The catalog numbers listed in the Type 4X column are for Type 4X 304-Grade stainless steel, as indicated by the **seventh** digit.
Example: ECX78D5AAA-_{_}. To order Type 4 painted steel, change that digit to **3**.
- ④ Handle mechanism is rated Type 1 or 12. Contact local sales office for availability of Type 4X versions.
- ⑤ Select proper "XTPR" MMP overload amperage range as per motor FLA, see **Page V10-T3-44**.